

SIP SMT16W-12

S E R I E S

16 AMP POL CONVERTERS

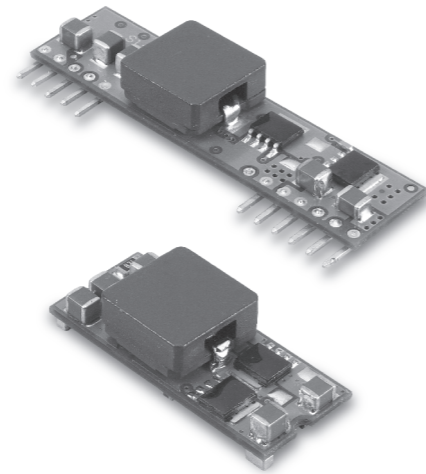

Features

- Non-Isolated POL Converter
- SIP / SMT Package
- Output Current 16AMP
- Input Voltage Range 6-14VDC
- Output Voltage Range 0.7525-5VDC
- 300KHz Switching Frequency
- High Efficiency to 94%
- Over Temperature Protection
- Continuous Short Circuit Protection
- Remote On/Off Control
- Output Voltage Sequencing
- Power Good Signal
- UL/c-UL 60950 Certified

MODEL NUMBER	INPUT VOLTAGE	OUTPUT VOLTAGE	OUTPUT CURRENT	INPUT CURRENT		% EFF.
				NO LOAD	FULL LOAD	
SIP 16W-12S05A	6.0-14VDC	0.7525VDC	16A	40mA	1250mA	80
	6.0-14VDC	1.2VDC	16A	40mA	1882mA	85
	6.0-14VDC	1.5VDC	16A	50mA	2273mA	88
	6.0-14VDC	1.8VDC	16A	60mA	2697mA	89
SMT16W-12S05A	6.0-14VDC	2.0VDC	16A	60mA	2963mA	90
	6.0-14VDC	2.5VDC	16A	65mA	3663mA	91
	6.0-14VDC	3.3VDC	16A	75mA	4731mA	93
	6.5-14VDC	5.0VDC	16A	95mA	7092mA	94

NOTE: 1. Nominal Input Voltage 12VDC

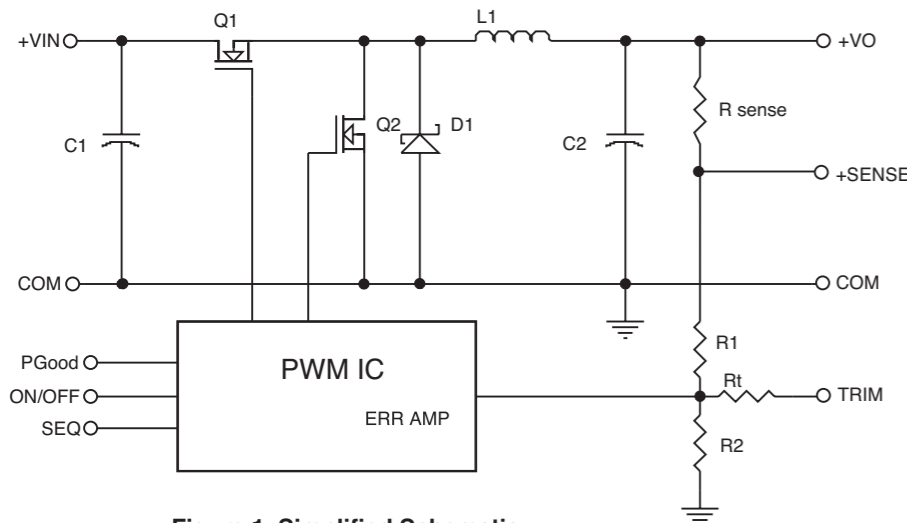

Figure 1. Simplified Schematic

Vo, set (V)	Rtrim (KΩ)
0.7525	Open
1.2	22.46
1.5	13.05
1.8	9.024
2.0	7.417
2.5	5.009
3.3	3.122
5.0	1.472

Table 1. External Resistor Values for programming output voltage

Specifications

INPUT SPECIFICATIONS:

Input Voltage Range.....12V.....6.0 – 14V
 12V.....6.5 – 14V
 Under Voltage Lock-outPower up5.0V Typ.
 Power down.....4.0V Typ.
 Input Filter Type.....Capacitive
 Positive Remote on/off Control :
 Module ON.....Open Circuit or = Vin
 Module OFF.....< 0.4 Vdc

OUTPUT SPECIFICATIONS:

Voltage Accuracy.....±1.5% max.
 Transient Response :25% Step Load Change.....<200µ sec.
 Ripple and Noise, 20MHz BW³.....30mV rms max.
 75mV pk-pk max.
 Temperature Coefficient.....±0.03%/C max.
 Short Circuit Protection.....Continuous
 Line Regulation¹.....± 0.2% max.
 Load Regulation².....± 0.5% max.
 External Trim Adj. Range (see Table 1).....Vo=0.75-5.0Vdc
 Sequencing Slew Rate Capability (dV_{seq}/dt).....0.1-1.0V/msec
 Sequencing Delay Time.....10msec min.
 Tracking Accuracy.....Power up.....200mV max.
 Power down.....400mV max.
 Capacitive Load, Low ESR.....8000µF max.
 Power Good Signal Asserted Logic High.....Vo=90%-100%Vo,nom

GENERAL SPECIFICATIONS:

Efficiency.....See Table
 Isolation Voltage.....Non-isolation
 Switching Frequency300KHz Typ.
 Over Temperature Protection130°C Typ.
 Operating Ambient Temperature Range.....-40°C to +85°C
 Power Derating Curvesee Figure 2,3
 Storage Temperature Range-55°C to +125°C
 Dimensions:
 SIP Package: 2.00 x 0.510 x 0.327 inches (50.8 x 12.95 x 8.30 mm)
 SMT Package: 1.30 x 0.530 x 0.346 inches (33.0 x 13.46 x 8.80 mm)
 Structure.....Non-potted With Open Frame Type
 Weight.....8.5g

SIP16W-12S05A Vo=3.3V Derating Curve

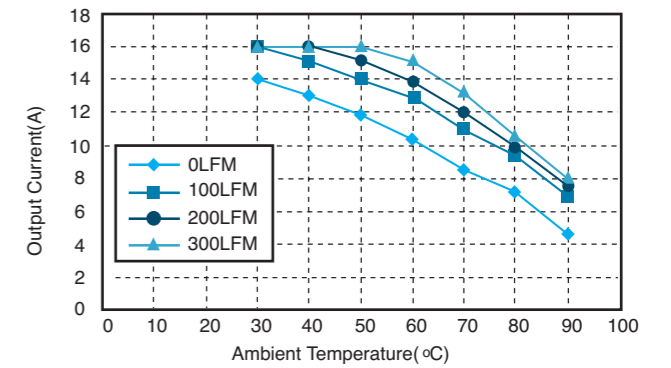

Figure 2. Typical Power De-rating for 12V IN

SMT16W-12S05A Vo=3.3V Derating Curve

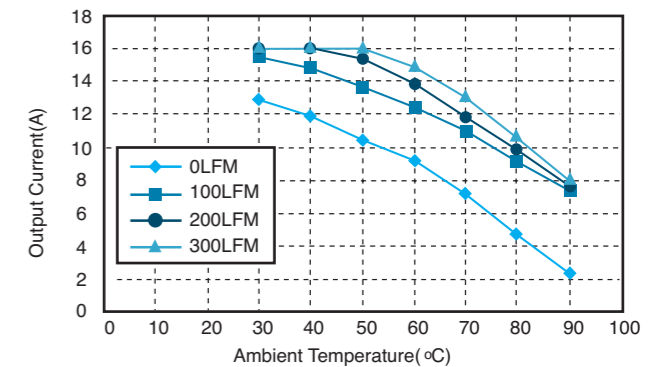

Figure 3. Typical Power De-rating for 12V IN

NOTE:

1. Measured From High Line to Low Line, Vo,set=3.3Vdc
2. Measured From Full Load to Zero Load, Vo,set=3.3Vdc
3. The output noise is measured with 10µf tantalum capacitor and 1µf ceramic capacitor across output.
4. The Input Terminal Recommend to Parallel With 100µF Capacitor ESR<100mΩ to Reduce The Input Ripple Voltage
5. Suffix "N" to the Model Number with Negative Logic Remote on/off
 Model ON.....Open Circuit or < 0.4VDC
 Module OFF.....>+2.8VDC to Vin
6. Suffix "P" to the Model Number with Power Good function.

Mechanical Specification

All Dimensions In Inches(mm)
 Tolerance Inches: x.xx= ±0.02, x.xxx= ±0.010
 Millimeters: x.x= ±0.5, x.xx= ±0.25

SIP Packages

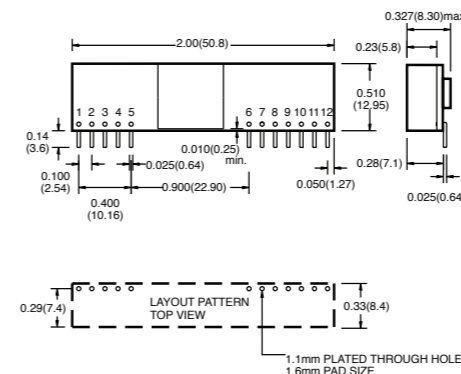

Pin	Function
1	+Output
2	+Output
3	+Sense
4	+Output
5	Common
6	No Pin / PGood
7	Common
8	+V Input
9	+V Input
10	Sequency
11	Trim
12	On/Off Control

SMT Packages BOTTOM VIEW OF BOARD

