

White LED Step-Up Converter With PWM Dimming Control

■ GENERAL DESCRIPTION

The **NJU6051** is a step-up DC/DC converter specially designed to drive white light emitting diodes (LEDs). The **NJU6051** drives four LEDs in series with an input voltage range of 3.0V to 5.5V (V_{DD}), and is interfaced to an MPU with a logic voltage range of 1.8V to 5.5V (V_{DDL}).

The **NJU6051** incorporates an LED current control that programs the LED current (I_{LED}) by use of an external resistor, a luminance sensor control, and a PWM (Pulse Width Modulation) dimming control that automatically adjusts the LEDs' brightness according to ambient luminance. The **NJU6051**'s reference voltage has temperature compensation that suppresses the characteristic degradation of the LEDs and provides the maximum performance of the LEDs at high temperatures.

In addition, the **NJU6051**'s current limit control and switching-off control permit the use of small, low-profile inductors and capacitors to minimize the footprint in space-conscious portable applications.

■ PACKAGE OUTLINE

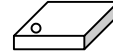

NJU6051***

■ FEATURES

- Drives up to Eight(4 x2) LEDs($I_{OUT}=30mA$ Max.)
- Built-in LED Current Control
- Built-in PWM Dimming Control
- Built-in Luminance Sensor Control
- Temperature Compensation Circuit
- Uses Small Inductor and Capacitors
- 3.0V to 5.5V Operating Voltage for Step-up Circuits
- 1.8V to 5.5V Operating Voltage for Logic Circuits
- CMOS Technology
- Package : P-CSP

NJU6051

■ BLOCK DIAGRAM

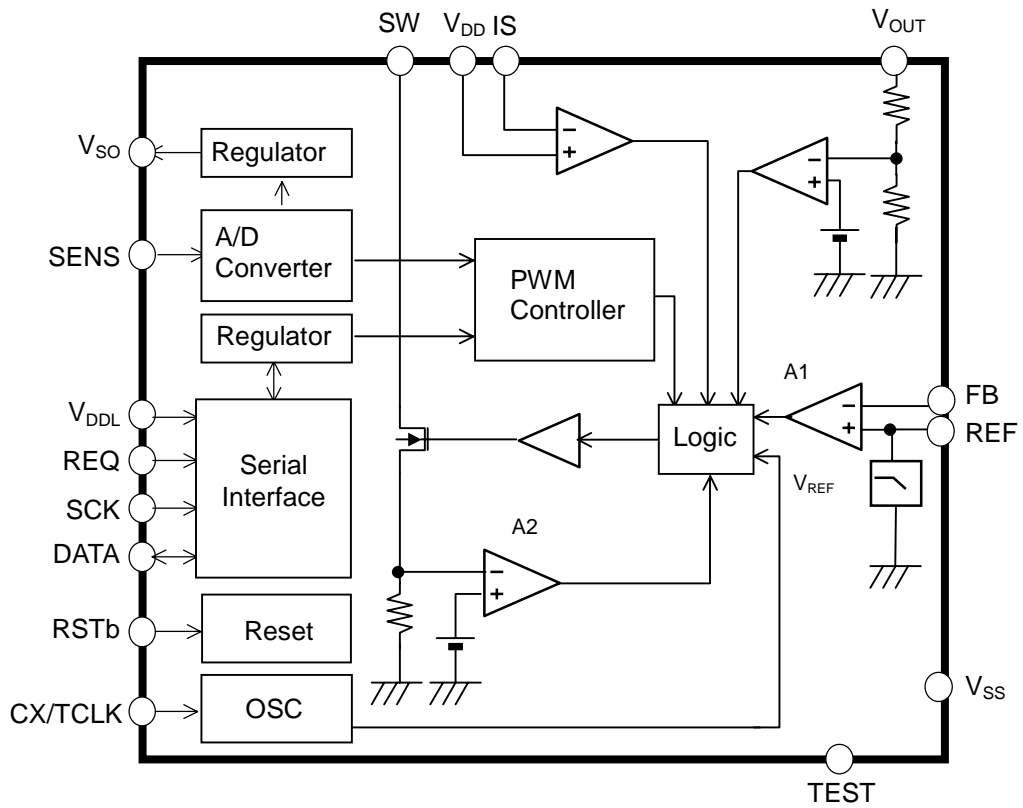

■ ABSOLUTE MAXIMUM RATINGS

Ta=25°C

PARAMETERS	SYMBOL	CONDITIONS	RATINGS	UNIT
VDD Power Supply	V _{DD}		-0.3 to +6	V
Input Voltage	V _I		-0.3 to V _{DDL} +0.3	V
VDD Input Voltage	V _{DD}		-0.3 to V _{DD} +0.3	V
VDDL Power Supply	V _{DDL}		-0.3 to V _{DD}	V
Switch Voltage	V _{SW}		-0.3 to +20	V
Output Voltage	V _{OUT}		-0.3 to +20	V
Feedback Voltage	V _{FB}		-0.3 to V _{DD} +0.3	V
Power Dissipation	PD		T.B.D.	mW
Operating Temperature	T _{opr}		-40 to +85	°C
Storage Temperature	T _{stg}		-55 to +125	°C

Note) The maximum voltage in the system is V_{SW} (V_{OUT}+V_F). V_F is the forward voltage of diode D1.

■ DC ELECTRICAL CHARACTERISTICS

V_{DD}=3.0 to 5.5V, Ta=-40 to 85°C

PARAMETERS	SYMBOL	CONDITIONS	RATINGS			Unit
			MIN.	TYP.	MAX.	
V _{DD} Power Supply	V _{DD}		3.0		5.5	V
V _{DDL} Power Supply	V _{DDL}		1.8		V _{DD}	V
Output Current	I _{OUT}	RLED=22Ω		30		mA
Output Voltage	V _{OUT}	C2=1uF		18.0		V
Reference Voltage	V _{REF}	Ta=25°C	0.42	0.44	0.46	V
Operating Current	I _{OP}	fosc=350kHz		T.B.D.		uA
Standby Current	I _{STBY}			T.B.D.		uA
V _{SO} Power Supply	V _{SO}		2.32	2.40	2.48	V
Sense Voltage range	V _{SENS}	SENS terminal	0		V _{DD}	V
Duty Change Voltage 1	V _{D1}	SENS terminal, REV=0 PWMREGSTER6 to 7	0.72V _{SO}	0.8V _{SO}	0.88V _{SO}	V
Duty Change Voltage 2	V _{D2}	SENS terminal, REV=0 PWMREGSTER5 to 6	0.36V _{SO}	0.4V _{SO}	0.44V _{SO}	V
Duty Change Voltage 3	V _{D3}	SENS terminal, REV=0 PWMREGSTER4 to 5	0.18V _{SO}	0.2V _{SO}	0.22V _{SO}	V
Duty Change Voltage 4	V _{D4}	SENS terminal, REV=0 PWMREGSTER3 to 4	0.09V _{SO}	0.1V _{SO}	0.11V _{SO}	V
Duty Change Voltage 5	V _{D5}	SENS terminal, REV=0 PWMREGSTER2 to 3	0.045 V _{SO}	0.05V _{SO}	0.055 V _{SO}	V
Duty Change Voltage 6	V _{D6}	SENS terminal, REV=0 PWMREGSTER1 to 2	0.0225 V _{SO}	0.025 V _{SO}	0.0275 V _{SO}	V
Duty Change Voltage 7	V _{D7}	SENS terminal, REV=0 PWMREGSTER0 to 1	0.01125 V _{SO}	0.0125 V _{SO}	0.01375 V _{SO}	V
Input "L" Level	V _{IL}	SCK, DATA, REQ, RSTB, TCLK terminals	0		0.2V _{DDL}	V
Input "H" Level	V _{IH}	SCK, DATA, REQ, RSTB, TCLK terminals	0.8V _{DDL}		V _{DDL}	V
Output "L" Level	V _{OL}	DATA terminals V _{DDL} =1.8V, I _{OL} =0.4mA			0.2V _{DDL}	V
Output "H" Level	V _{OH}	DATA terminals V _{DDL} =1.8V, I _{OH} =-0.04mA	0.8V _{DDL}			V
Oscillation Frequency	f _{OSC}	V _{DD} =3V, CX=68pF	300	350	400	kHz
Oscillation Duty	DOSC	V _{DD} =3V, CX=68pF		80		%

NJU6051

APPLICATION CIRCUIT

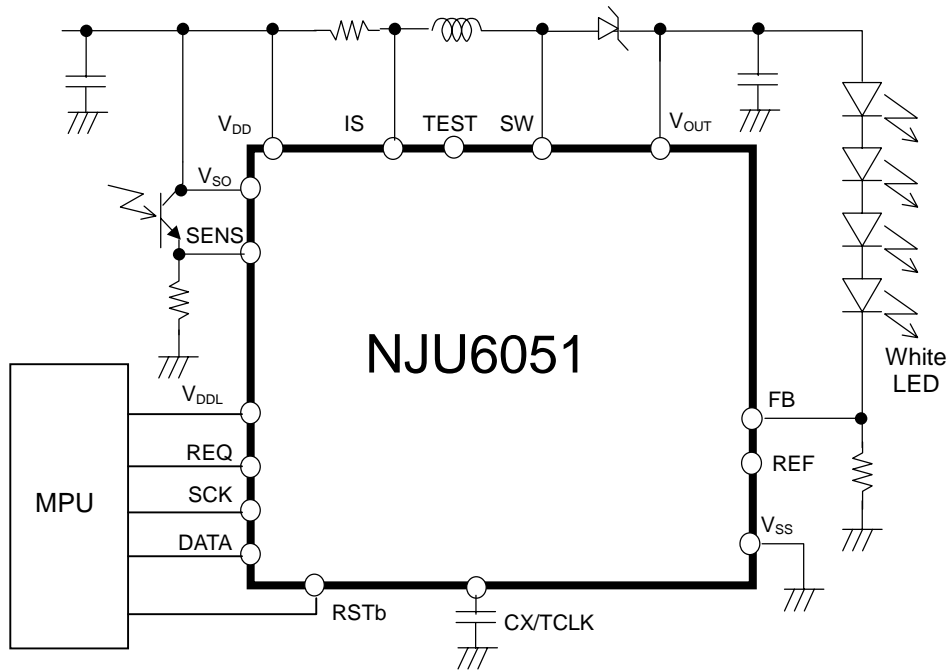

[CAUTION]
The specifications on this databook are only given for information, without any guarantee as regards either mistakes or omissions. The application circuits in this databook are described only to show representative usages of the product and not intended for the guarantee or permission of any right including the industrial rights.