

THREE-PHASE DC BRUSHLESS MOTOR CONTROL IC

GENERAL DESCRIPTION

The NJW4302 is a three-phase DC brushless motor pre-driver IC for precision applications.

The NJW4302 consists of PWM driver, motor velocity control, FG(Frequency Generator) output, and voltage velocity integration circuit.

The NJW4302 realizes stabilized velocity and it is suitable for printer, FAX, and other DC motor control systems.

PACKAGE OUTLINE

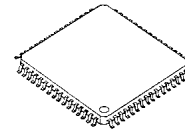

NJW4302FG1

FEATURES

- Speed discriminator and PLL speed control circuit
- Direct PWM driver
- CR oscillator
- Lock protection output
- Break circuit (short circuit braking)
- Start/stop switch Start/Stop Switch Circuit
- Current limit circuit
- Thermal shut down/Under voltage lockout circuit
- FG output amplifier/Integrating circuit
- Shunt regulator output : 5V
- Bi-CMOS technology
- PACKAGE OUTLINE QFP64G1

PIN CONFIGURATION

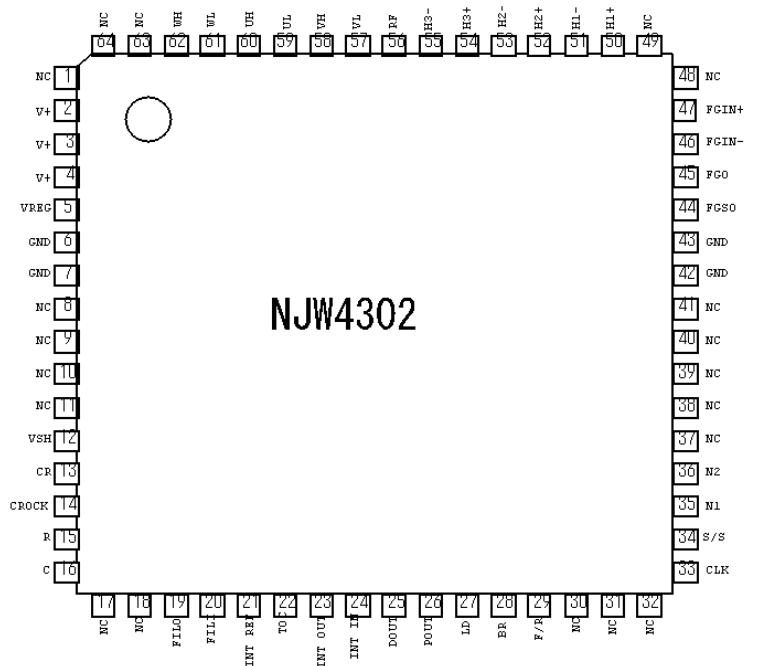

BLOCK DIAGRAM

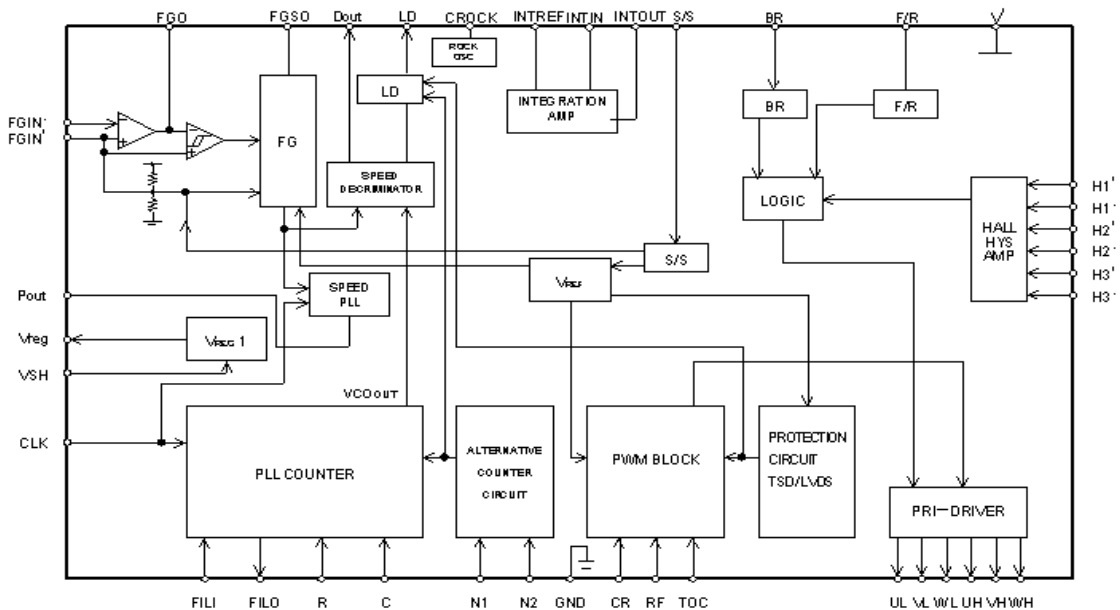

NJW4302

■PIN DESCRIPTION

SYMBOL	PIN No.	DESCRIPTION
H1+,H1- H2+,H2- H3+,H3-	50, 51 52, 53 54, 55	Hall input pins Positive input terminal is defined as IN ⁺ , Negative input terminal as IN ⁻ respectively. Positive input is defined as IN ⁺ > IN ⁻ as Negative.
UH VH WH	58 60 62	Output pins(for fixed current source)
UL VL WL	57 59 61	Output pins(open collector sink outputs). Duty control implement with PWM signal.
V ⁺	2~4	Power-supply voltage pin Connect a noise decoupling capacitor between these pins and the ground.
VREG	5	Shunt regulator output pin
GND	6,7 42,43	Ground pins These pins are all connected internally to the ground(GND).
VSH	12	Shunt regulator ON/OFF output pin “L”:ON “H” or open:OFF
CR	13	PWM oscillator frequency setting pin Three blocks use the oscillator: motor constraint detection circuit, clock disconnection protection circuit and others
CROCK	14	Reference clock signal oscillator pin Connect a capacitor between this pin to the ground.This oscillator provides clock signal when motor is locked.
R	15	VCO oscillation frequency setting pin Connect a resistor between this pin and the ground.
C	16	VCO oscillation frequency setting pin Connect a resistor between this pin and ground. Set the value of the capacitor so that the oscillator frequency does not exceed 1MHz.
FILI	20	VCO filter amplifier input pin This pin is connected to VCO PLL output with 10KΩ resistor internally in the IC.
FILO	19	VCO filter amplifier output pin This pin is connected to VCO circuit internally in the IC.
D OUT	25	Speed discriminator output pin Output“L”level for over speed.
P OUT	26	PLL output pin Output the phase comparison result for 1/2fCLK and 1/2fFG.
LD	27	Lock detection output pin Open collector becomes“L”within the speed lock range(±6.25).
INT REF	21	Integrating amplifier forward rotation input(a potential of 1/2V ⁺)
INT IN	24	Negative input for Integration amplifier
INT OUT	23	Output for Integration amplifier
TOC	22	Torque command input pin This pin is normally connected to the INT OUT pin. When the TOC voltage level falls,the UL,VL and WI PWM duties are changed to increase.
FG IN+	47	Input pin for FG amplifier forward rotation (a potential of 1/2V ⁺) Connect a noise decoupling capacitor between V ⁺ terminal and the ground.

FG IN-	46	FG amplifier reverse rotation input.
FGO	45	FG amplifier output.
FGSO	44	FG amplifier output(after the schmitt) Open collector output.
RF	56	Output current detection Connect a resistor between this pin and GND pin.The output limitation maximum current(IOUT)is set to be 0.5/Rf.
S/S	34	Start-Stop control "L":Start "H"or Open:Stop
F/R	29	Forward/reverse rotation control "L":Forward "H"or Open:reverse
BR	28	Brake control (short braking operation) "L":Start "H"or Open:Brake
CLK	33	External clock signal input 10kHz max.
N1	35	Speed discriminator count switching
N2	36	
NC	1,8~11 17,18,30~32 37~41,48,49 63,64	Non Connection

NJW4302

■ FUNCTIONAL DESCRIPTION

1. VCO circuit

The variable range of PLL circuit is determined by two factors: VCO frequency determined by RC value connected to Pin 15 and Pin 16 and VCO loop filter constants. VCO frequency range must be within 160kHz to 1.0MHz.

The typical external value is as follows:

$$R=20k\Omega, C=100pF.$$

The filter constants are $C=0.47\mu F, R=27k\Omega$.

2. Output drive circuit

The PWM control is made by upper side of external transistor.

3. Speed lock range

The speed lock range is $\pm 6.25\%$ of fixed speed. When the motor speed is within the lock range, the LD pin (an open collector output) goes "L". If the motor speed goes out of the lock range, the LD pin goes "H".

Please be noted that the LD signal may go on during startup.

4. PWM frequency

The PWM frequency is determined by resistor and capacitor value connected to the CR pin.

The PWM frequency can be expressed as:

$$f_{PWM} = 1 / (0.48CR)$$

When $C=1500pF, R=75K\Omega$, the PWM frequency goes about 19KHz.

5. Lock detection circuit(CLOCK)

Lock detection circuit protects the driver IC and the motor from fatal over current failure when the motor is locked during startup. If the LD output remains "H" (motor lock state) for a certain period (Hold time), all phase of upper side transistors are to be turned off.

The hold time can be programmed by capacitor value attached to the CLOCK pin by the following:

$$\text{Set time(sec)} = 66 \times C(\mu F)$$

With $C=0.068\mu F$, the hold time can be programmed for approximately 4.5 sec.

Once Lock detection circuit is activated, the state remains unchanged unless it is turned off, or stopped.

This function can be disabled when the CLOCK pin is connected to the ground.

6. Forward / Reverse(F/R)Switching

The direction control can be made with the state of the F/R pin. The direction can be changed even during the motor in motion.

7. Brake Switch

NJW4302 uses a short brake method that turns on all phase of upper side transistors for braking. During the time, all lower side transistors are turned off.

8. VREG pin/VSH pin

NJW4302 includes a regulator to generate for +5V regulated IC supply when the motor drive circuit is designed with a single power supply. The VREG pin and V+ pin compose a shunt regulator for $5V \pm 5\%$ output with a external resistor and a transistor. To use the regulator, the VSH pin must be either "H", or Open. Otherwise, the VSH pin must be "L" and the VREG pin is to be opened.

9. Frequency Generator (FG) Amplifier

The internal FG amplifier with few passive components composes a filter amplifier shown in the application. Circuit for noise rejection. The output voltage of the amplifier must be at least 250mA p-p since it feature Schmitt comparator.

The capacitor connected between the FGIN+ pin and the ground is necessary for bias voltage stabilization and initial reset pulse generation for the internal logic. The reset pulse is generated when the FGIN+ pin goes from 0 to about 1.25V.

10. Integrating Amplifier

The integrating amplifier integrates the D-out and P-out and converts them to speed command voltage.

During the time, it also sets the control loop gain and frequency characteristics using external components.

11. Speed Control Circuit

NJW4302 features two speed control method; speed discriminator circuit with PLL circuit and phase comparison circuit. The FG pulse frequency is controlled to be the same frequency with a clock frequency input to the CLK pin. Therefore, the motor speed can be controlled by changing the clock frequency.

The motor speed (N) can be expressed as:

$$N = \text{CLK (Hz)} \times (60/\text{FGP}) [\text{RPM}] \quad (\text{FGP: Number of FG pulse per one rotation})$$

Given that the oscillation frequency range is 160kHz~1.0MHz and the number of counts is 1024, the range of clock frequency is 156Hz~960Hz, and therefore the motor speed can be changed from 260rpm to 1600rpm.

NJW4302

■ABSOLUTE MAXIMUM RATING

PARAMETER	SYMBOL	TEST CONDITION	RATINGS	UNIT
Maximum supply voltage	V+		7	V
Maximum input current	Ireg	Vreg pin(5.6V)	10	mA
Output current	Io	UL,VL,WL	30	mA
Operating temperature	Topr		-40~85	°C
Storage temperature	Tstg		-55~150	°C
Power dissipation	Pd		700	mW

■ALLOWABLE MAXIMUM RANGES/Ta=25°C

PARAMETER	SYMBOL	CONDITION	RATINGS	UNIT
Input current range	I _{REG}	V _{REG} pin=5.6V	1.0~5.0	mA
FG Schmitt output applied voltage	V _{FGSO}		0~8	V
FG Schmitt output current	I _{FGSO}		0~5	mA
Lock detection output current	I _{LD}		0~20	mA
Supply voltage	V ⁺		4.5~5.5	V

■ELECTRICAL CHARACTERISTICS/Ta=25°C,V+=5.0V

PARAMETER	SYMBOL	CONDITION	MIN.	TYP.	MAX.	UNIT
Supply current 1	I _{CC1}		-	38	55	mA
Supply current 2	I _{CC2}	in stop mode	-	8	18	mA
Output saturation voltage	V _{O(sat)}	UL,VL and WL terminal I _o =20mA	-	0.2	0.7	V
Output current	I _o	UH,VH and WH terminal V _{out} =1.4V	-20	-16	-12	mA
Output leakage current	I _{o(leak)}	UL,VL,WL output	-	-	100	μA
Output off voltage	V _{O(off)}	UH,VH,WH output	-	-	0.5	V

●HALL AMPLIFIER

PARAMETER	SYMBOL	TEST CONDITION	MIN.	TYP.	MAX.	UNIT
Input bias current	I _{HB(HA)}		-4	-1	-	μA
Common mode input voltage range	V _{ICM}		1.5	-	V _{CC} -1.5	V
Hall input sensitivity	ΔV _{IN(HA)}		60	-	-	mV _{P-P}
Hysteresis	ΔV _{IN(HA)}		17	32	60	mV
Input voltage Low → High	V _{SLH}		8	16	30	mV
Input voltage High →Low	V _{SHL}		-30	-16	-8	mV

●CR OSCILLATOR

PARAMETER	SYMBOL	TEST CONDITION	MIN.	TYP.	MAX.	UNIT
Output high level voltage	V _{OH(CR)}		2.4	2.7	3.0	V
Output low level voltage	V _{OL(CR)}		1.3	1.6	1.9	V
RC oscillation frequency	f(CR)	R=75kΩ,C=1500pF	-	19	-	kHz
RC oscillation voltage	V(CR)		0.9	1.1	1.3	V _{P-P}

●CLOCK OSCILLATOR

PARAMETER	SYMBOL	TEST CONDITION	MIN.	TYP.	MAX.	UNIT
Output high level voltage	V _{OH(RK)}		2.7	3.0	3.3	V
Output low level voltage	V _{OL(RK)}		0.1	0.4	0.7	V
External capacitor charge current	I _{CHG1}		-14	-10	-6	μA
External capacitor discharge current	I _{CHG2}		6	10	14	μA
Clock oscillation frequency	f(RK)	C=0.068μF	-	35	-	Hz
RC oscillation voltage	V(RK)		2.4	2.6	2.8	V _{P-P}

●VCO OSCILLATOR(PLL COUNTER)

PARAMETER	SYMBOL	TEST CONDITION	MIN.	TYP.	MAX.	UNIT
C-terminal high-level output voltage	V _{OH(C)}		1.15	1.25	1.35	V
C-terminal low-level output voltage	V _{OL(C)}		0.9	1.0	1.1	V
VCO oscillation frequency	f(C)		-	-	1.0	MHz
Amplitude	V(C)		0.15	0.25	0.6	V _{P-P}

NJW4302

•CURRENT LIMITING OPERATION

PARAMETER	SYMBOL	TEST CONDITION	MIN.	TYP.	MAX.	UNIT
Limiter	V _{RF}		0.47	0.52	0.57	V

•FG AMPLIFIER

PARAMETER	SYMBOL	TEST CONDITION	MIN.	TYP.	MAX.	UNIT
Input offset voltage	V _{IO} (FG)		-10	0	10	mV
Input bias current	I _B (FG)		-1	0	1	μA
Output low-level voltage	V _{OH} (FG)		V ⁺ -1.5	V ⁺ -1.0	-	V
Output high-level voltage	V _{OL} (FG)		-	1	1.5	V
FG input sensitivity	ΔV _{IN} (FG)	GAIN =40dB	3	-	-	mV
Schmitt amplifier for next stage	ΔV _{SH} (FG)		100	180	250	mV
Operating frequency range	ΔFG		-	16	-	kHz
Open loop gain	A _V (FG)	f(FG)=2kHz	-	51	-	dB

•FGSO OUTPUT

PARAMETER	SYMBOL	TEST CONDITION	MIN.	TYP.	MAX.	UNIT
Output saturation voltage	V _O (FGSO)	I _O (FGS)=2mA	-	0.1	0.5	V
Output leak current	I _L (FGSO)	V _O =V ⁺	-	-	10	μA

•SPEED DISCRIMINATOR OUTPUT(Dout)

PARAMETER	SYMBOL	TEST CONDITION	MIN.	TYP.	MAX.	UNIT
Output high-level voltage	V _{OH} (D)		V ⁺ -1.0	V ⁺ -0.7	-	V
Output low-level voltage	V _{OL} (D)		-	0.4	1.1	V

•SPEED CONTROL PLL OUTPUT (Pout)

PARAMETER	SYMBOL	TEST CONDITION	MIN.	TYP.	MAX.	UNIT
Output high-level voltage	V _{OH} (P)		3.35	3.65	3.95	V
Output low-level voltage	V _{OL} (P)		1.35	1.65	1.95	V

•LOCK DETECTION (LD)

PARAMETER	SYMBOL	TEST CONDITION	MIN.	TYP.	MAX.	UNIT
Output saturation voltage	V _{OL} (LD)	I _{LD} =10mA	-	0.1	0.5	V
Output leak current	I _L (LD)	V _O =V ⁺	-	-	10	μA
Lock range	ΔLOCK		-6.25	-	+6.25	%

•INTEGRATER AMPLIFIER

PARAMETER	SYMBOL	TEST CONDITION	MIN.	TYP.	MAX.	UNIT
Input offset voltage	V _{IO} (INT)		-10	-	10	mV
Input bias current	I _B (INT)		-0.4	-	0.4	μA
Output high-level voltage	V _{OH} (INT)		V ⁺ -0.12	V ⁺ -0.8	-	V
Output low-level voltage	V _{OL} (INT)		-	0.8	1.2	V
Open loop gain	A _V (INT)		-	60	-	dB
Gain-band width product	GBW(INT)		-	1.6	-	MHz
Reference voltage	V _B (INT)		2.375	2.5	2.625	V

•FILTER AMPLIFIER (PLL COUNTER)

PARAMETER	SYMBOL	TEST CONDITION	MIN.	TYP.	MAX.	UNIT
Input bias current	I _B (FIL)		-0.4	-	0.4	μA
Output high-level voltage	V _{OH} (FIL)		V ⁺ -1.2	V ⁺ -0.8	-	V
Output low-level voltage	V _{OL} (FIL)		-	0.8	1.2	V
Hysteresis	V _B (FIL)		2.375	2.5	2.625	V

•S/S AMPLIFIER

PARAMETER	SYMBOL	TEST CONDITION	MIN.	TYP.	MAX.	UNIT
Input high-level voltage	V _{IH} (S/S)		3.5	4.2	V ⁺	V
Input low-level voltage	V _{IL} (S/S)		0	0.8	1.0	V
Hysteresis	ΔV _{IN} (S/S)		1.0	1.3	1.6	V
Pull-Up resistance	R _U (S/S)		60	80	100	kΩ

•F/R AMPLIFIER

PARAMETER	SYMBOL	TEST CONDITION	MIN.	TYP.	MAX.	UNIT
Input high-level voltage	V _{IH} (F/R)		3.5	4.2	V ⁺	V
Input low-level voltage	V _{IL} (F/R)		0	0.8	1.0	V
Hysteresis	ΔV _{IN} (F/R)		1.0	1.3	1.6	V
Pull-Up resistance	R _U (F/R)		60	80	100	kΩ

•BR AMPLIFIER

PARAMETER	SYMBOL	TEST CONDITION	MIN.	TPY.	MAX.	UNIT
Input high-level voltage	V _{IH} (BR)		3.5	4.2	V ⁺	V
Input low-level voltage	V _{IL} (BR)		0	0.8	1.0	V
Hysteresis	ΔV _{IN} (BR)		1.0	1.3	1.6	V
Pull-Up resistance	R _U (BR)		60	80	100	kΩ

NJW4302

•CLK AMPLIFIER

PARAMETER	SYMBOL	TEST CONDITION	MIN.	TPY.	MAX.	UNIT
Input high-level voltage	VIH(CLK)		3.5	4.2	V ⁺	V
Input low-level voltage	VIL(CLK)		0	0.8	1.0	V
Hysteresis	Δ VIN(CLK)		1.0	1.3	1.6	V
Pull-Up resistance	RU(CLK)		60	80	100	k Ω
Input frequency	f(CLK)		-	16	-	kHz

•N1 AMPLIFIER

PARAMETER	SYMBOL	TEST CONDITION	MIN.	TYP.	MAX.	UNIT
Input high-level voltage	VIH(N1)		3.5	4.2	V ⁺	V
Input low-level voltage	VIL(N1)		0	0.8	1.0	V
Hysteresis	Δ VIN(N1)		1.0	1.3	1.6	V
Pull-Up resistance	RU(N1)		60	80	100	k Ω

•N2 AMPLIFIER

PARAMETER	SYMBOL	TEST CONDITION	MIN.	TYP.	MAX.	UNIT
Input high-level voltage	VIH(N2)		3.5	4.2	V ⁺	V
Input low-level voltage	VIL(N2)		0	0.8	1.0	V
Hysteresis	Δ VIN(N2)		1.0	1.3	1.6	V
Pull-Up resistance	RU(N2)		60	80	100	k Ω

•UNDER VOLTAGE LOCKOUT

PARAMETER	SYMBOL	TEST CONDITION	MIN.	TYP.	MAX.	UNIT
Operating voltage	VSDL		-	3.75	-	V
Release voltage	VSDH		-	4.0	-	V
Hysteresis	Δ VSD		0.15	0.25	0.35	V

•SHUNT REGULATOR

PARAMETER	SYMBOL	TEST CONDITION	MIN.	TYP.	MAX.	UNIT
Output voltage	VO(VSH)		4.75	5.0	5.25	V

•VSH AMPLIFIER

PARAMETER	SYMBOL	TEST CONDITION	MIN.	TYP.	MAX.	UNIT
Input high-level voltage	VIH(VSH)		3.5	4.2	V ⁺	V
Input low-level voltage	VIL(VSH)		0	0.8	1.0	V
Hysteresis	Δ VIN(VSH)		1.0	1.3	1.6	V
Pull-Up resistance	RU(VSH)		60	80	100	k Ω

■ SPEED DISCRIMINATOR COUNT TABLE

N1	N2	NUMBER OF COUNTS
High or Open	High or Open	128
High or Open	Low	512
Low	High or Open	256
Low	Low	1024

■ THREE PHASE LOGIC TRUTH TABLE

	F/R=L			F/R=H			OUTPUTS	
	H 1	H 2	H 3	H 1	H 2	H 3	Source	Sink
1	H	L	H	L	H	L	VH	UL
2	H	L	L	L	H	H	WH	UL
3	H	H	L	L	L	H	WH	VL
4	L	H	L	H	L	H	UH	VL
5	L	H	H	H	L	L	UH	WL
6	L	L	H	H	H	L	VH	WL

■ S/S TERMINAL

High or Open	Stop
Low	Start

■ BRAKE TERMINAL

High or Open	Brake
Low	Release

NJW4302

■ TYPICAL APPLICATION

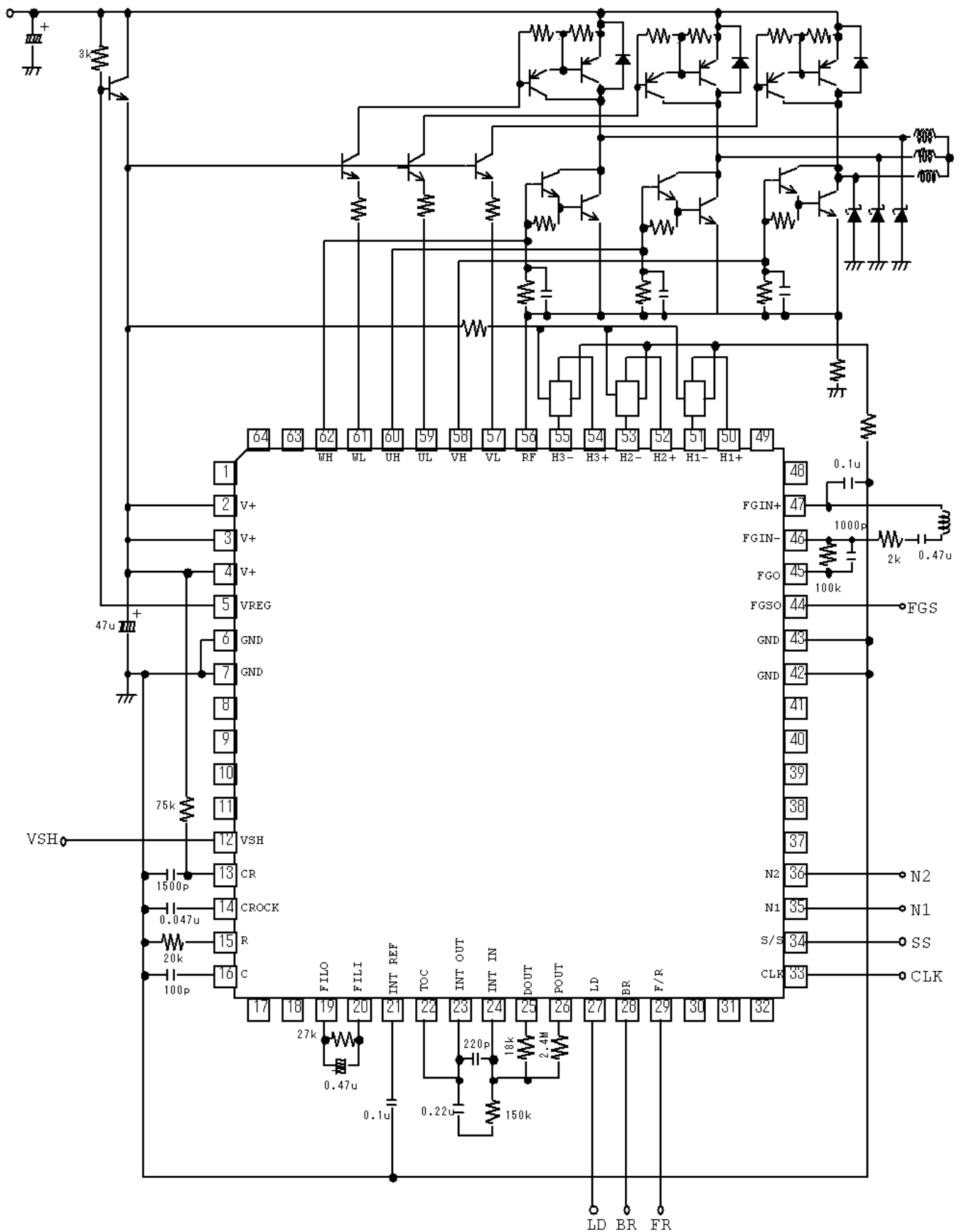

■ TYPICAL CHARACTERISTICS

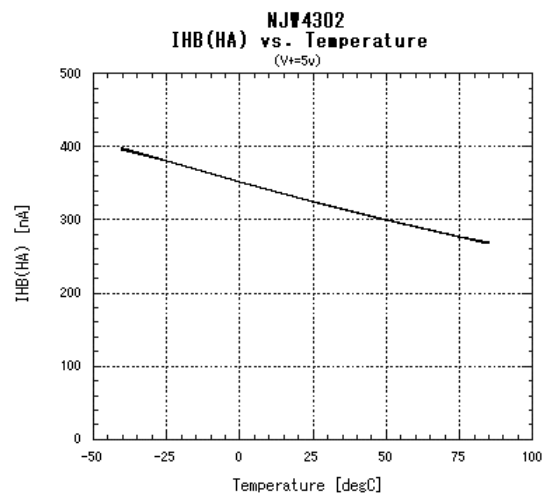
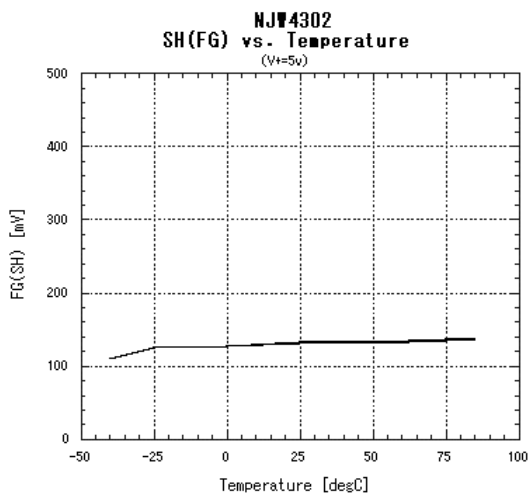
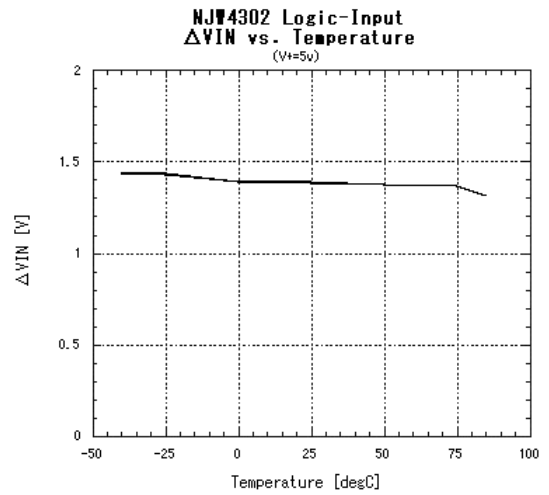
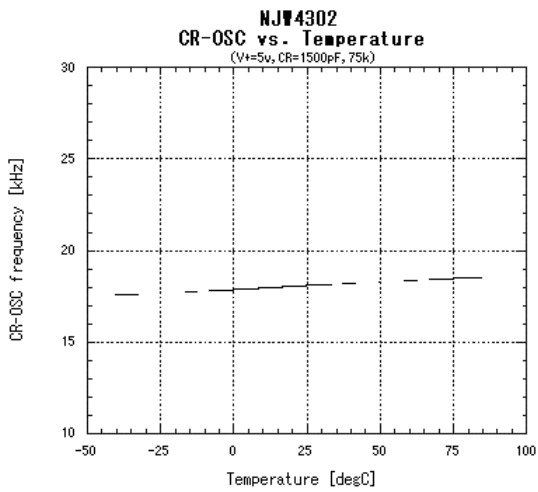
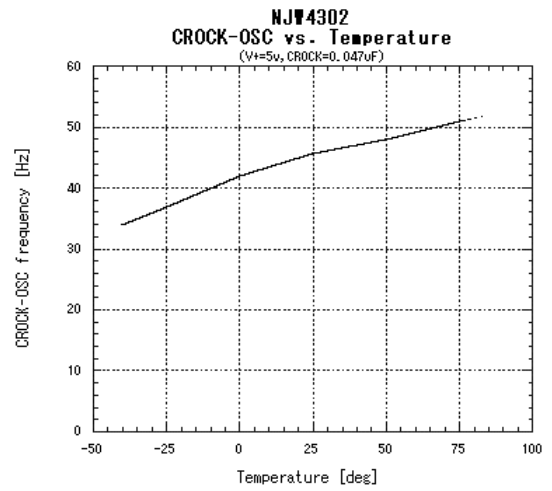
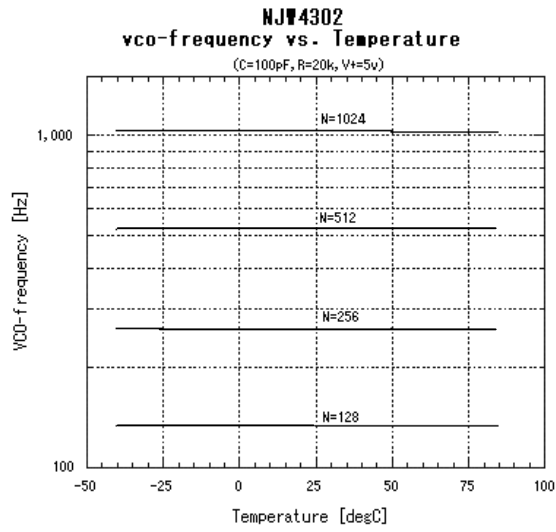

NJW4302

■ TYPICAL CHARACTERISTICS

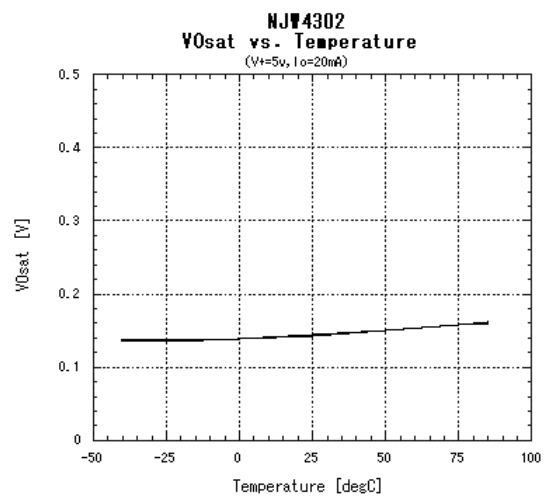
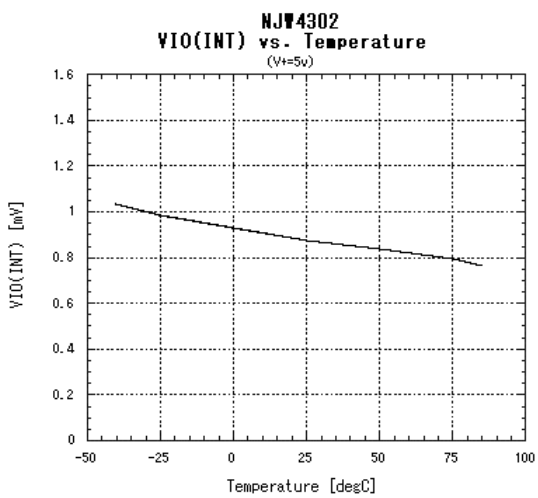
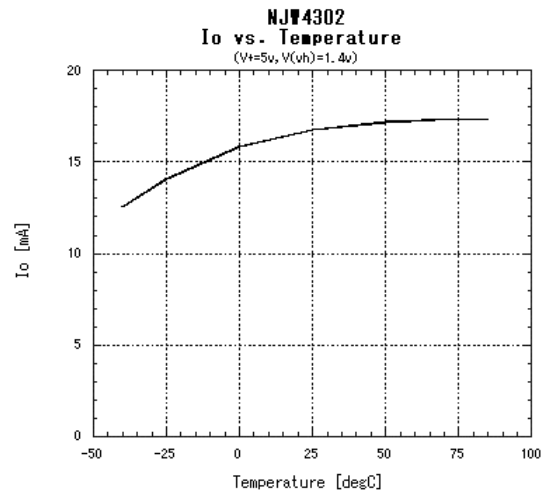
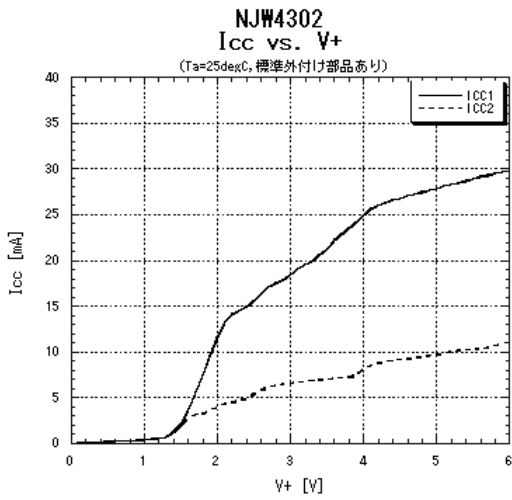
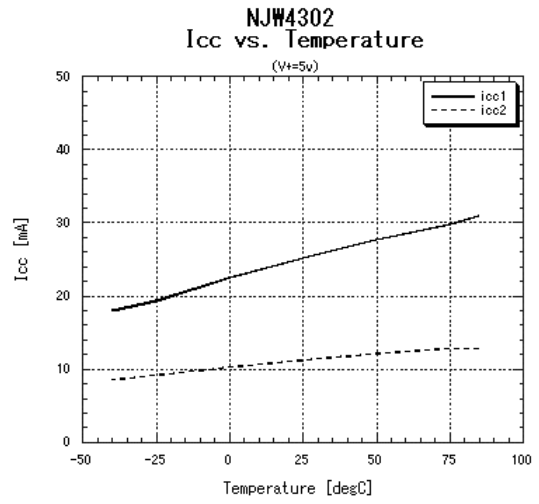
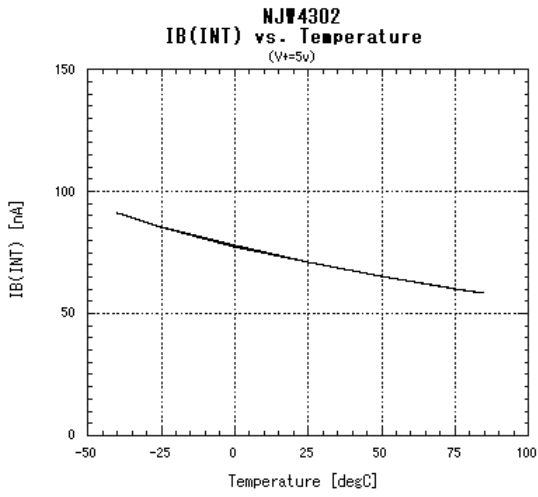

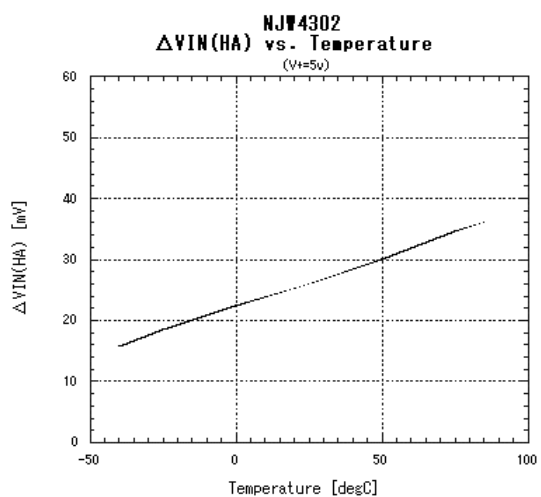

The specifications on this data book are only given for information, without any guarantee as regards either mistakes or omissions. The application circuit in this data book are described only to show representative usages of the product and not intended for the guarantee or permission of any right including the industrial rights.