

## TRAY DIMENSIONS

(1) Hard Tray Dimensions for QFP44-A1, QFP56-A1

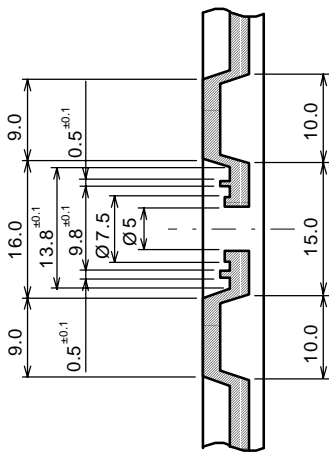

BB Cross Section

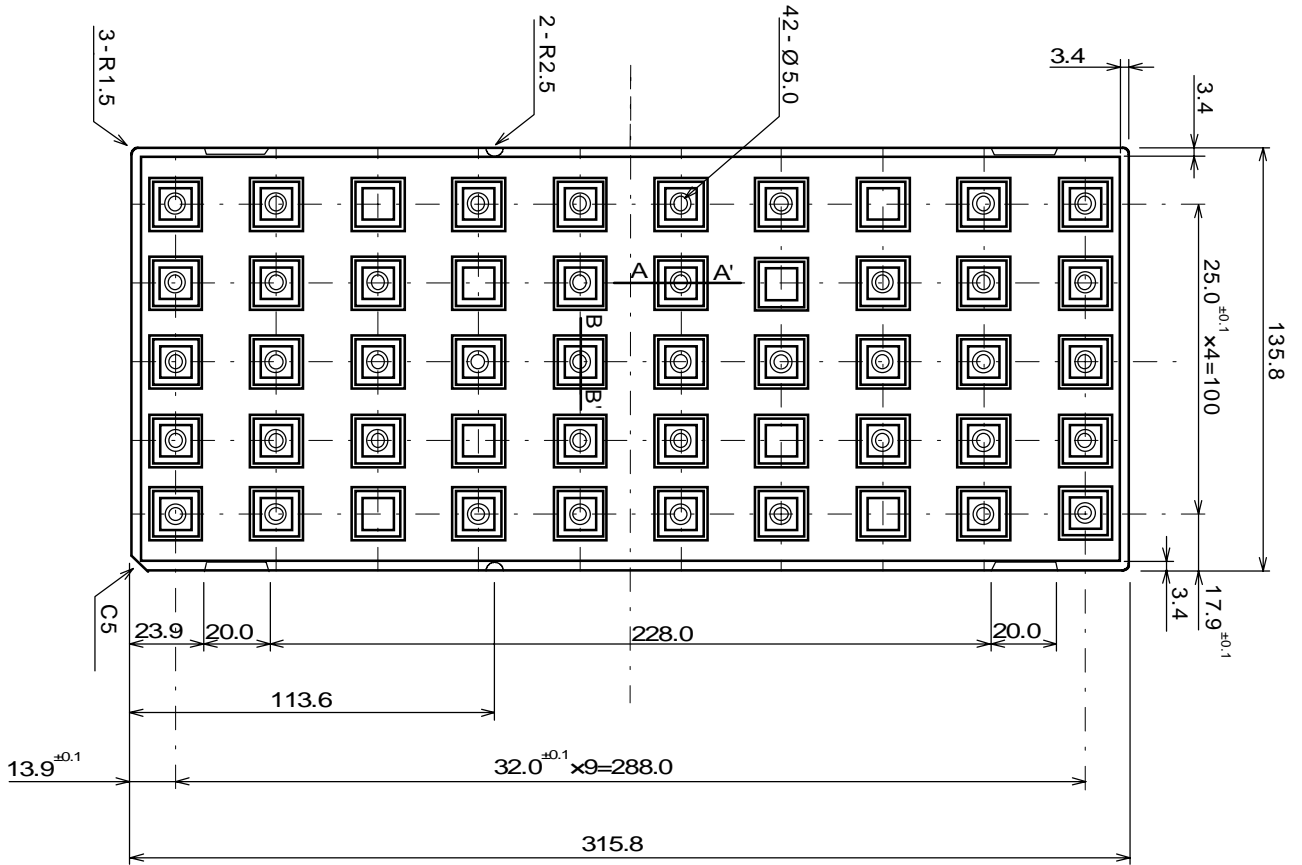
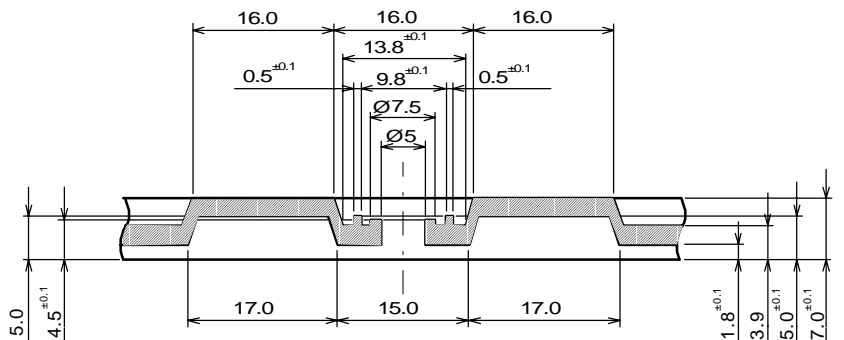

AA Cross Section

Unit : mm

Material	Polypropylene (Anti Electrostatic treatment)
Maximum Contents	50pcs

# TRAY DIMENSIONS

(2) Hard Tray Dimensions for QFP64-B2

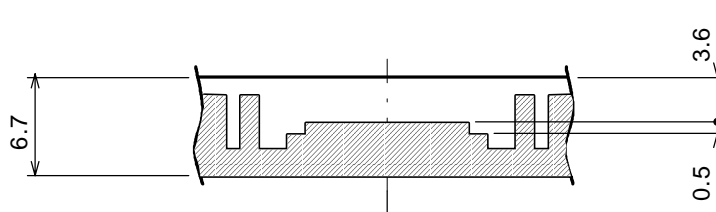
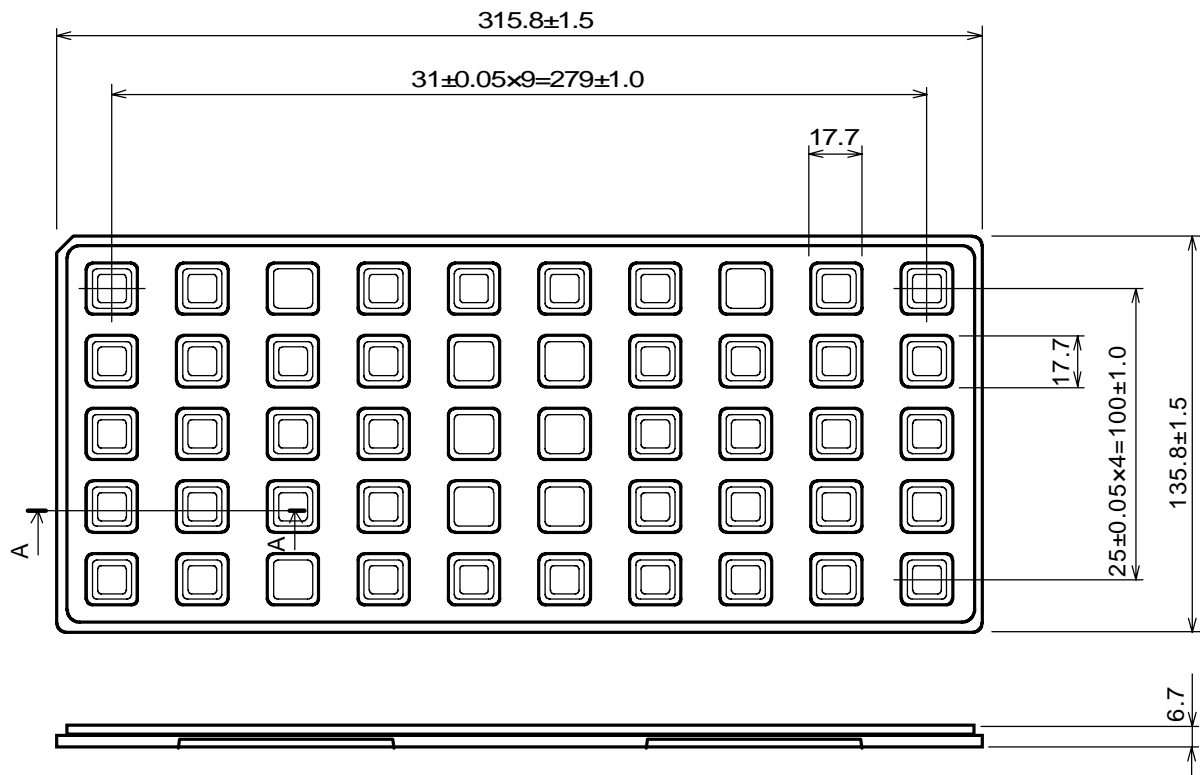

AA Cross Section

Unit : mm

Maximum Contents	50pcs
------------------	-------

# TRAY DIMENSIONS

## (3) Hard Tray Dimensions for QFP64-B3

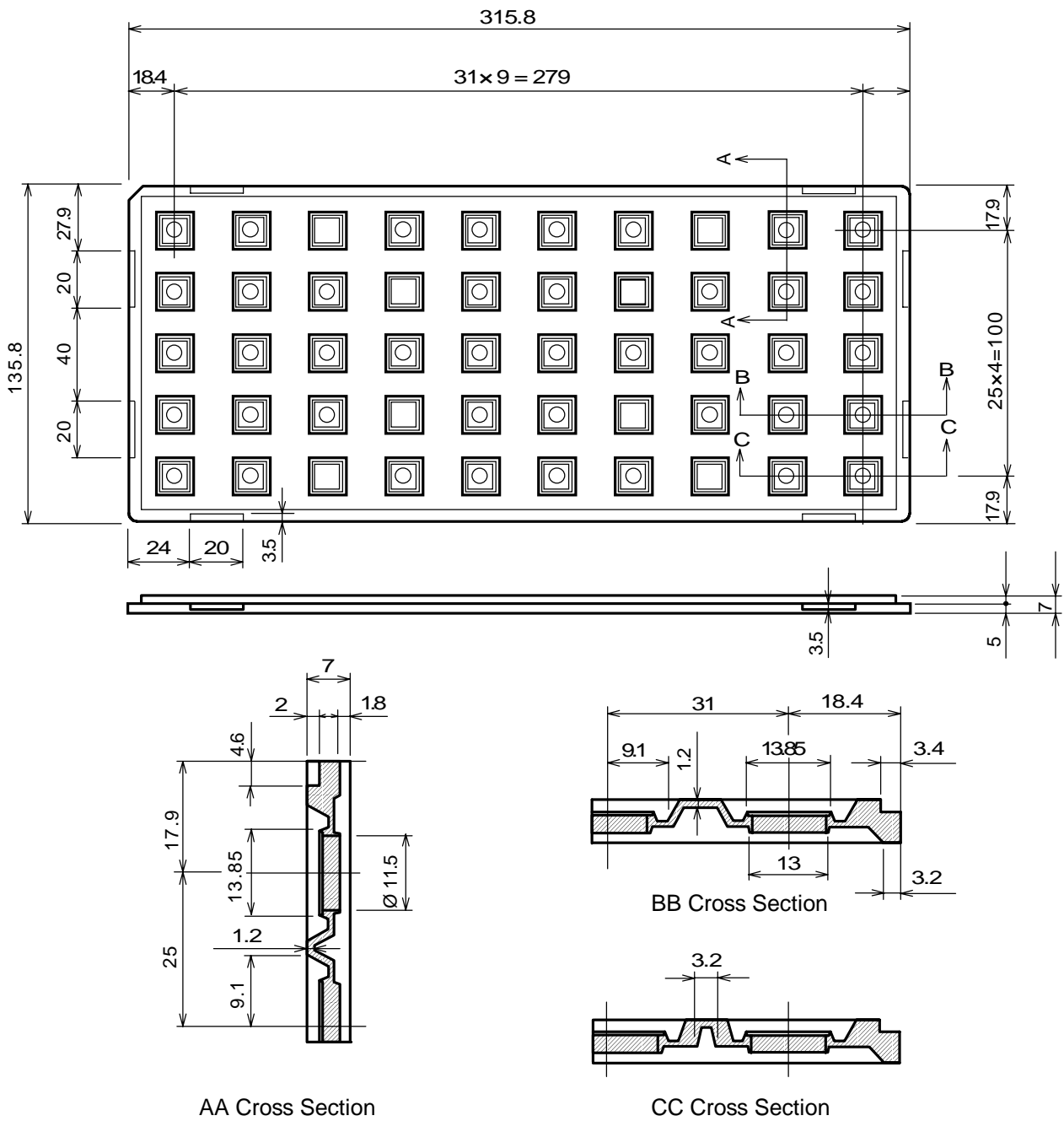

Unit : mm

Material	Conductive Resin
Maximum Contents	50pcs

# TRAY DIMENSIONS

(4) Hard Tray Dimensions for QFP64-C1/C2, QFP80-C1(1),(2)/C2(1),(2), QFP100-C1(1),(2)/C2

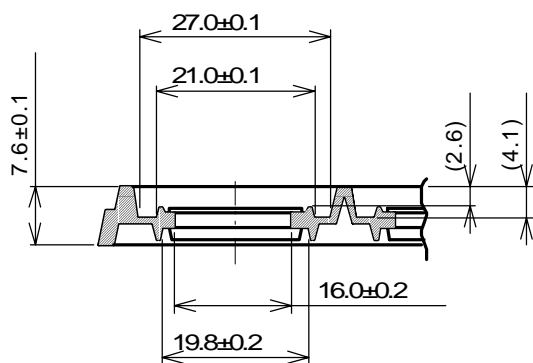
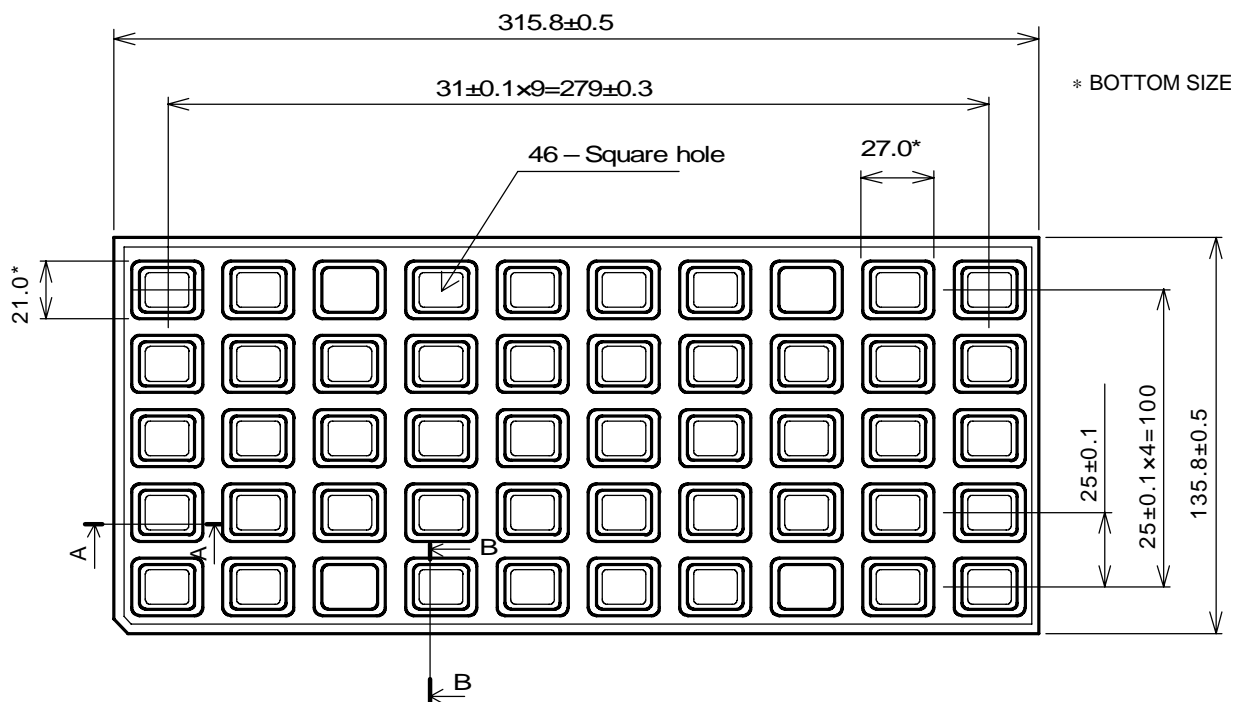

AA Cross Section

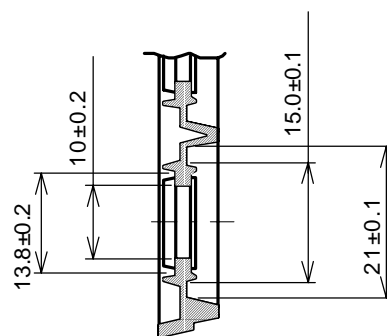

BB Cross Section

Unit : mm

Material	Polystyrene (Anti Electrostatic treatment)
Maximum Contents	50pcs

# TRAY DIMENSIONS

## (5) Hard Tray Dimensions for QFP64-D1

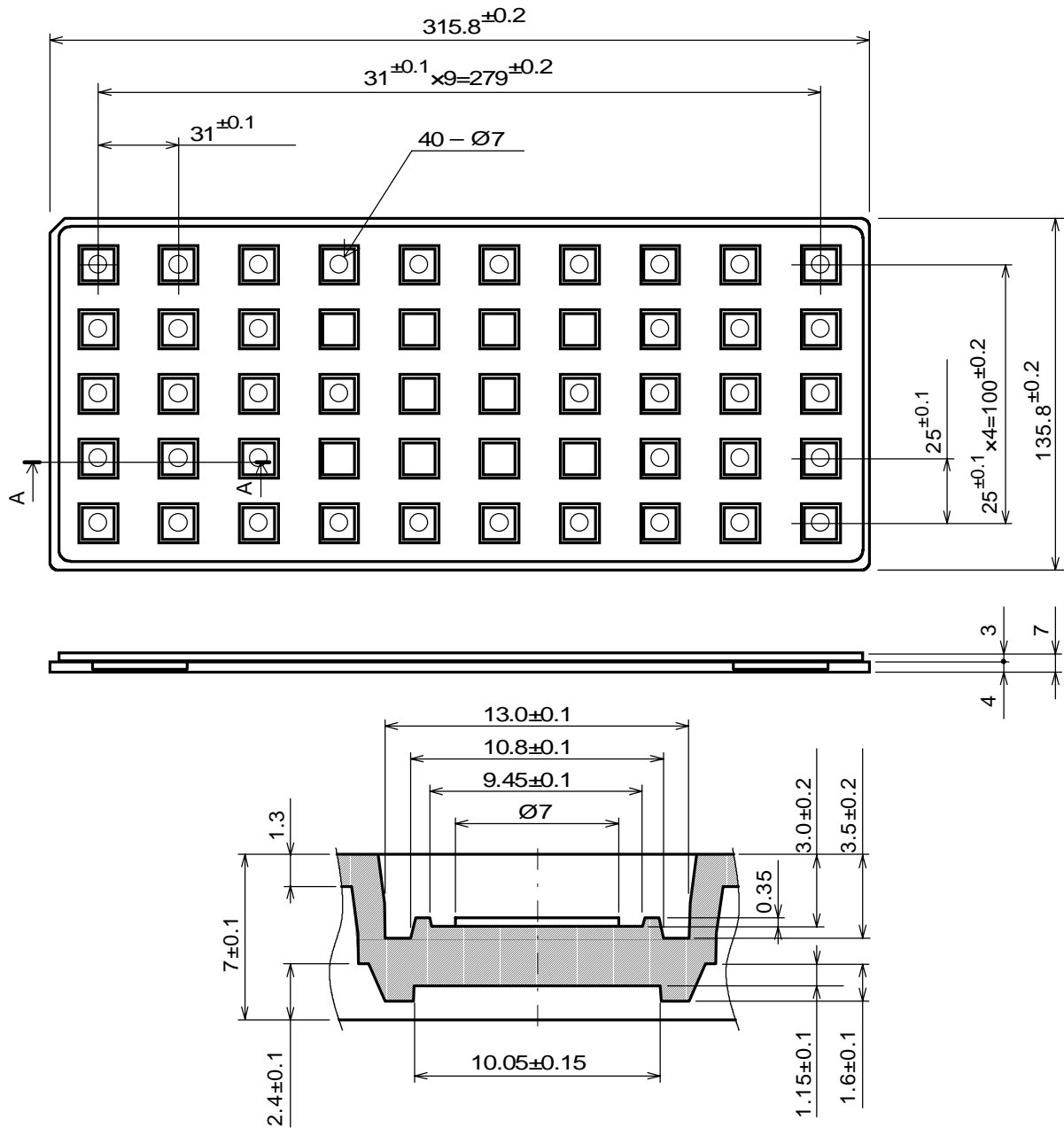

AA Cross Section

Unit : mm

Material	Polystyrene
Maximum Contents	50pcs

# TRAY DIMENSIONS

(6) Hard Tray Dimensions for QFP64-G1, QFP80-G1, QFP100-G1

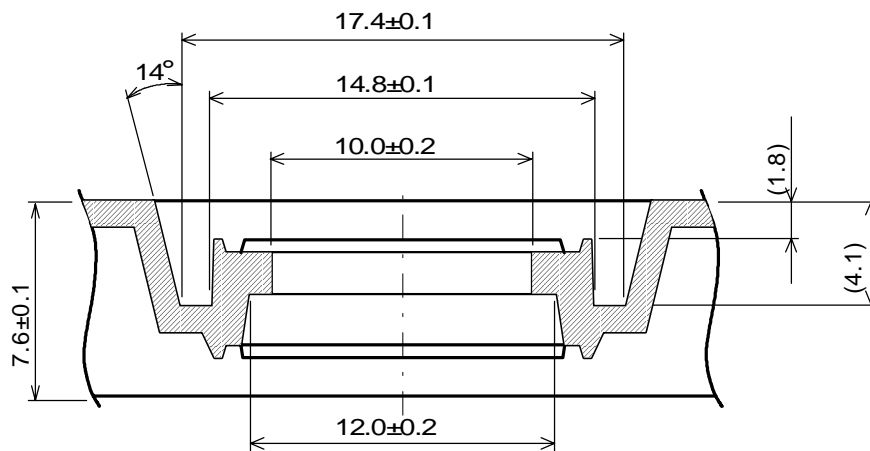
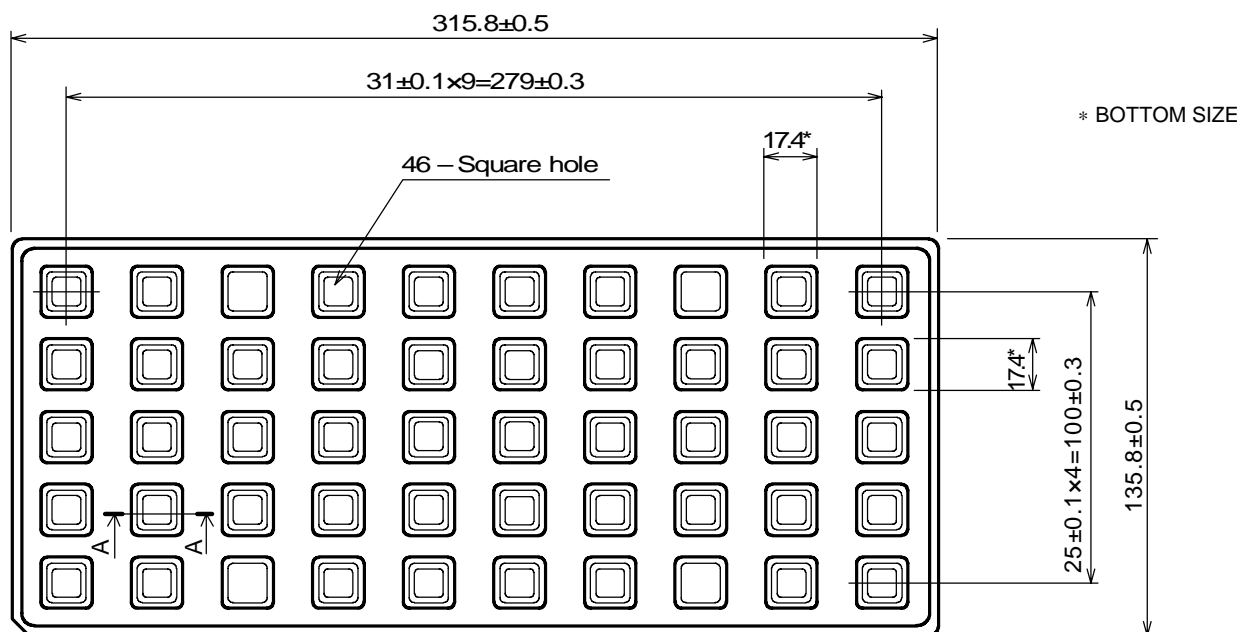

AA Cross Section

Unit : mm

Material	Polypropylene (Anti Electrostatic treatment)
Maximum Contents	50pcs

# TRAY DIMENSIONS

## (7) Hard Tray Dimensions for QFP80-C2(3)

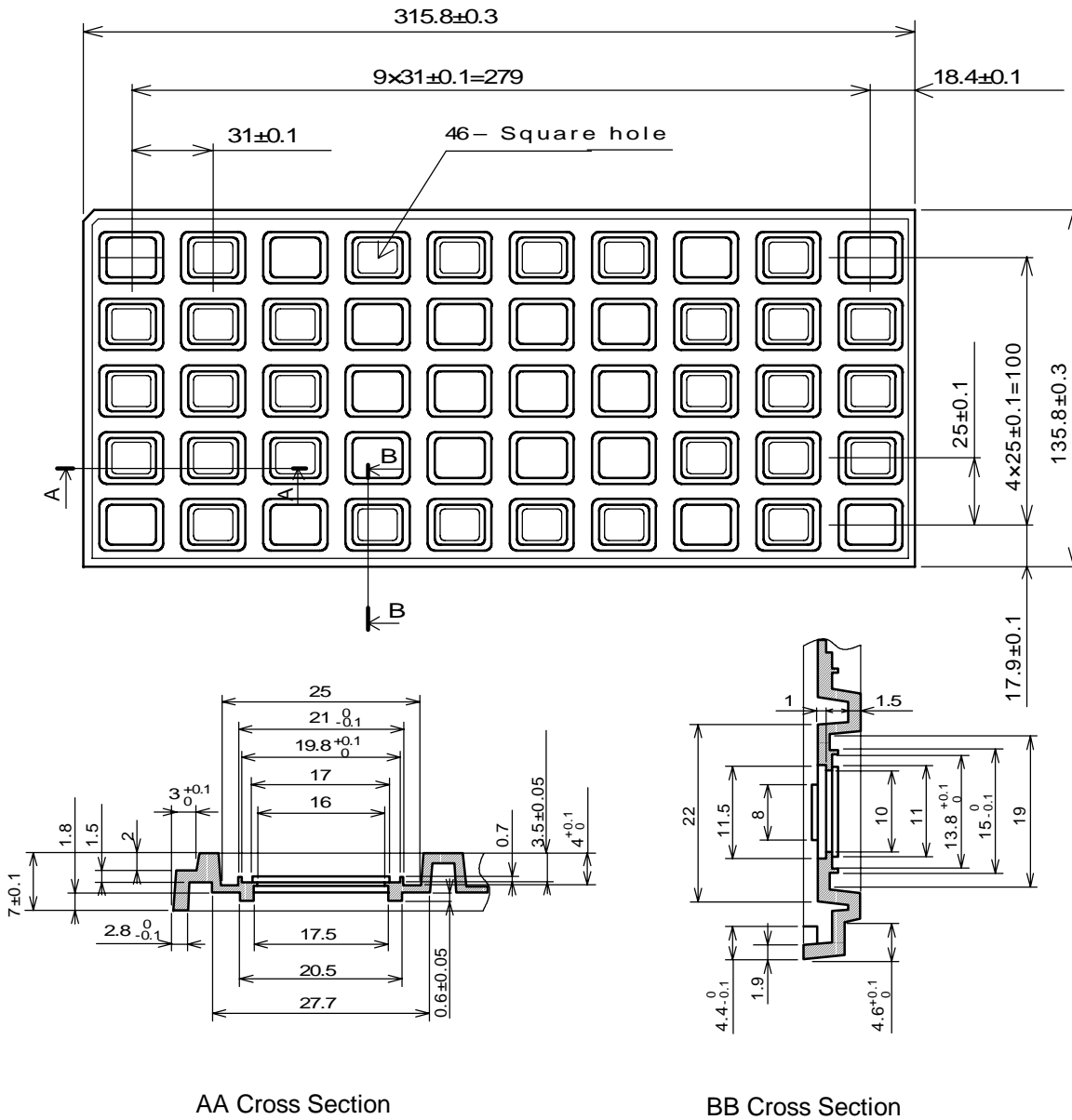

Unit : mm

Material	PPE
Maximum Contents	50pcs