



Slimline Power Supply

User Configurable 1U size



patents pending



Slimline

PLUG & PLAY POWER next generation power source

FEATURES

- Slimmest 400W configurable power
- Extra low profile: 1U height (40mm)
- All outputs fully floating
- Ultra high efficiency, up to 89%
- Plug & Play Power
 - allows fast custom configuration
 - allow easy logistics
- FLEXIMOUNT Flexible mounting system
- Few electrolytic capacitors (all long life)
- Visual LED indicators
- Series / Parallel of multiple outputs
- 5V bias standby voltage provided
- Individual output control signals

APPLICATIONS INCLUDE

- Industrial machines
- Test and measurement
- Automation equipment
- Printing
- Telecommunications
- For Medical applications see Xmite

The Xlite family of power supplies provides up to 600W in a slimline 1U x 260 x 89mm package. Providing up to 8 isolated outputs, the Xlite family is the most flexible power supply in its class and brings affordable configurable power to the 200-600W market.

The slimline product boasts unrivalled power density saving valuable system space. Combine with ultra high efficiencies, the Xlite family provides system designers with flexible instant solutions that significantly shorten and simplify system design-in time.

The Xlite family consists of 3 *powerPac* models in 200W, 400W and 600W power levels. Each *powerPac* model may be populated with up to 4 *powerMods* selected from the table of *powerMods* shown below.

All configurations carry full safety agency approvals, UL60950, EN60950 and are CE marked. For alternative power interfaces contact support@excelsys.com

powerMods

MODEL	Vmin	Vnom	Vmax	I _{max}	Watts*
Xg1	1.5	2.5	3.6	50A	125W
Xg2	3.2	5.0	6.0	40A	200W
Xg3	6.0	12.0	15.0	20A	240W
Xg4	12.0	24.0	30.0	10A	240W
Xg5	28.0	48.0	58.0	6A	288W
Xg7	5.0	24.0	28.0	5A	120W
Xg8	v1	5.0	24.0	3A	72W
	v2	5.0	24.0	3A	72W

powerPacs

	MODEL	Watts
Xlite	XLA	200W
	XLB	400W
	XLC	600W

*see datasheet *powerMods* for full output module specifications
powerMod ratings when used with Xlite *powerPac*

EFFICIENCY (typical)

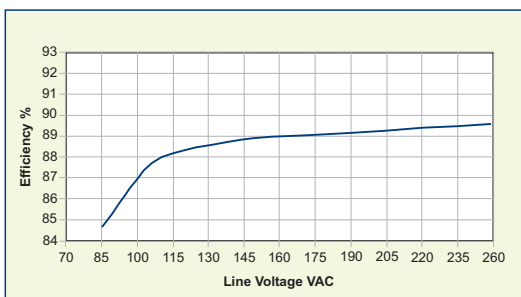

MECHANICAL SPECIFICATIONS

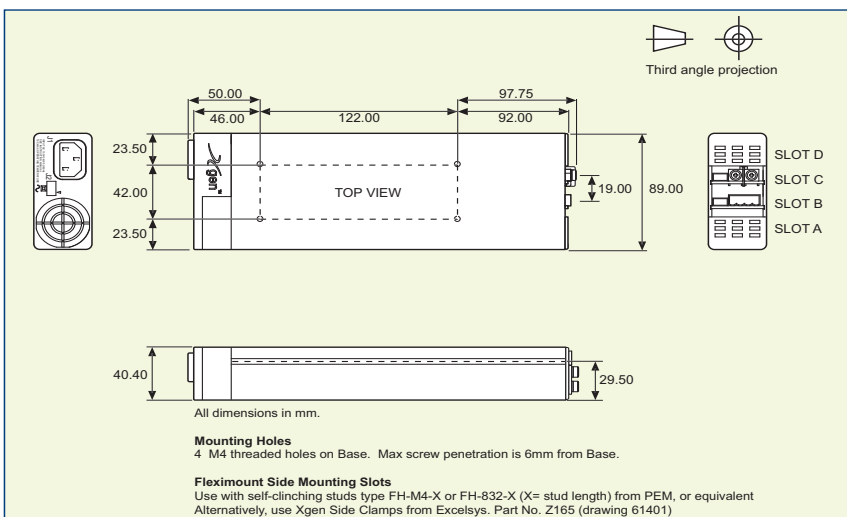

SPECIFICATION applies to configured units consisting of **powerMods** modules plugged into the appropriate **powerPac**

INPUT					
Parameter	Conditions/Description	Min	Nom	Max	Units
Input Voltage Range	Universal Input	85		264	VAC
		120		380	VDC
Input Frequency Range		47		63	Hz
Power Rating	XLA			200	W
	XLB			400	W
	XLC	Derate linearly from 600W at 180VAC to 400W at 85VAC		600	W
Input Current	XLA	85VAC in 200W out	4.0		A
	XLB	85VAC in 400W out	7.5		A
	XLC	85VAC in 400W out	7.5		A
Inrush Current	230VAC @ 25°C			20	A
Undervoltage Lockout	Shutdown	70		78	VAC
Fusing	XLA	250V 5 x 20mm		F5A HRC	
	XLB	250V 5 x 20mm		F8A HRC	
	XLC	250V 5 x 20mm		F8A HRC	

OUTPUT					
Parameter	Conditions/Description	Min	Nom	Max	Units
powerMod Power	As per powerMod table				
Output Adjustment Range	Manual: Multi-turn potentiometer. As per powerMod table				
	Electronic: See Xgen Designers' Manual				
Minimum Load			0		A
Line Regulation	For ±10% change from nominal line			±0.1	%
Load Regulation	For 25% to 75% load change			±0.2	%
Cross Regulation				±0.2	%
Transient Response	For 25% to 75% load change	Voltage Deviation		10	%
				Settling Time	250
Ripple and Noise	20MHz Bandwidth			1.0	% pk-pk
Overvoltage Protection	Two-level. 1st level: Vset Tracking. 2nd level: Vmax (Latching)	110		125	%
Overcurrent Protection	Straight line with hiccup activation at <30% of Vnom See powerMod datasheet and Designer's Manual for full details	110		120	%
Remote Sense	Max. line drop compensation. (except Xg7, Xg8)			0.5	VDC
Overshoot				2	%
Turn-on Delay	From AC In / Enable signal			300 / 30	ms
Rise Time	Monotonic			5	ms
Hold-up Time	For nominal output voltages at full load	20			ms
Output Isolation	Output to Output / Output to Chassis	500 / 500			VDC

GENERAL					
Parameter	Conditions/Description	Min	Nom	Max	Units
Isolation Voltage	Input to Output	3000			VAC
		1500			VAC
Efficiency	230VAC, 400W @ 24V		89		%
Safety Agency Approvals	EN60950, UL60950, CSA22.2 No.950 UL File No. E181875				
Leakage Current	250VAC, 60Hz, 25°C			1.5	mA
Signals	See Xgen Series datasheet				
Bias Supply	Always ON. Current 250mA	4.9	5.0	5.1	VDC
Reliability	Failures per million hours at 25°C and full load See Designers' Manual. powerPac excludes fans	powerMod powerPac		1.0	fpmh
				0.5	fpmh

EMC					
Parameter	Standard		Level		Units
Emissions					
Conducted	EN55011, EN55022, FCC		Level B		
Radiated	EN55011, EN55022, FCC		Level B		
Harmonic Distortion	EN61000-3-2		Compliant		
Flicker and Fluctuation	EN61000-3-3		Compliant		
Immunity					
Electrostatic Discharge	EN61000-4-2		Level 4		
Radiated RFI	EN61000-4-3		Level 3		
Fast Transients - burst	EN61000-4-4		Level 4		
Input Line Surges	EN61000-4-5		Class 4		
Conducted RFI	EN61000-4-6		10		V/m
Voltage Dips	EN61000-4-11 (EN55024)		10		ms

ENVIRONMENTAL					
Parameter	Conditions/Description	Min	Nom	Max	Units
Operating Temperature	Full Load up to 50°C. See derating below.	-20		+70	°C
Storage Temperature		-40		+85	°C
Derating	2.5% per °C above 50°C				
Relative Humidity	Non-condensing	5		95	%RH
Shock	3000 Bumps, 10G (16ms) half sine				
Vibration	1.5G	10		200	Hz

- NOTES**
1. This product is not intended for use as a stand alone unit and must be installed by qualified personnel.
 2. The specifications contained herein are believed to be correct at time of publication and are subject to change without notice.
 3. All specifications at nominal input, full load, 25°C unless otherwise stated.

Doc. 40038 rev. 02 12/06



Europe/Asia
 Excelsys Technologies Ltd t: +353 21 4354716
 27 Eastgate Drive f: +353 21 4354864
 Eastgate Business Park e: sales@excelsys.com
 Little Island, Cork, Ireland
 IRELAND

North America
 Excelsys Technologies t: (972) 771 4544
 519 Interstate 30, #309 f: (972) 421 1805
 Rockwall, TX 75087 e: salesusa@excelsys.com
 USA