



Electrolytic Capacitors Application Guide

CONTENTS

1	Principal application areas	3
2	Electrical model	3
3	Thermal equivalent circuit and mounting recommendations	3
4	Series and parallel connections	4
5	Calculate operational life time	5
6	Avoid destroying the capacitor	7
7	Intermittent operation	8
8	Calculation examples	8
9	Operational life time equations	12
10	www.evovx-rifa.com	13

1 Principal application areas

The main application areas for Evox Rifa electrolytic capacitors are for the

Axial types (PEG):

- Telecom, Lighting, Automotive
- Central switching systems, Electronic ballast, Control units

Can types (PEH):

- Power Electronics Industry
- Drives, Traction, Welding, SMPS, UPS

2 Electrical model

An electric equivalent schema of an electrolytic capacitor can be described as an equivalent series resistance (ESR), equivalent series inductance (ESL), the capacitance (C) and a parallel resistance for the leakage current (R_{leak}).

R_{leak} depends on the quality of the dielectric.

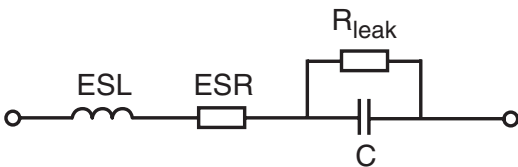

When the capacitor is charged and discharged there will be some electrons stored in the dielectric. When the discharge mechanism is removed these electrons start to build up a voltage, i.e. dielectric absorption. If this causes problems, it's possible to get capacitors with a short circuit tape between the terminals.

The current through the capacitor will cause a power loss in it, due mainly to the ESR.

$$P_{LOSS} = I_{RMS}^2 \times ESR$$

ESR decreases with increasing hot-spot temperature and with increasing frequency. The hot-spot is the hottest point in the winding.

ESR as a Function of Temperature and Frequency

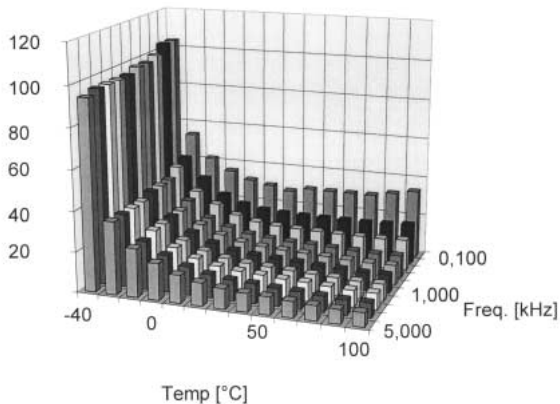

When the current consists of mains frequency and its harmonics, you have to calculate the power loss for each harmonic and sum them to have the total power loss in the capacitor.

$$P_{tot} = P_{(1)} + P_{(2)} + P_{(3)} + \dots + P_{(n)} = I_{(1)}^2 \times ESR_{(1)} + I_{(2)}^2 \times ESR_{(2)} + I_{(3)}^2 \times ESR_{(3)} + \dots + I_{(n)}^2 \times ESR_{(n)}$$

The power loss causes the temperature to rise in the capacitor. The temperature at the hot-spot (T_h) is decisive for the operational life (L_{OP}) of the capacitor. Increasing T_h leads to decreasing L_{OP} . To calculate T_h the thermal resistance (R_{th}) has to be known. At very high frequencies ESL has to be taken into consideration.

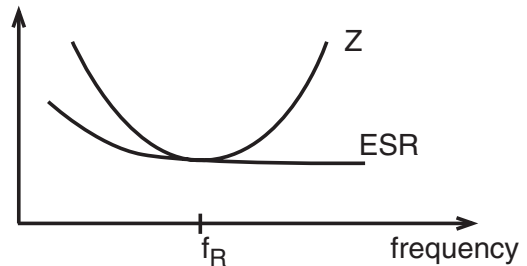

The resonant frequency (f_R) depends on the capacitor. For PEG it can be from 20 kHz up to more than 1 MHz and for PEH it can vary from 1.5 kHz to 150 kHz. If the capacitor is used at a frequency greater than the resonant frequency the capacitor works like an inductor.

3 Thermal equivalent circuit and mounting recommendations

The hot-spot is the hottest point in the capacitor, with temperature T_h . Heat will always be transported to the area with lower temperature. From the hot-spot to the ambient there are several ways for the heat to travel. Heat will be transferred through the aluminium foil and the electrolyte. If the capacitor is mounted on a heat-sink some of the heat will go through the heat-sink to the ambient. The total thermal resistance from hot-spot to ambient is called R_{th} . Below are examples of different R_{th} for clip mounted, stud mounted on a heat-sink with a thermal resistance of $2^\circ\text{C}/\text{W}$, and a capacitor stud mounted on a heat-sink with a thermal resistance of $2^\circ\text{C}/\text{W}$ with forced air of velocity 2 m/s. This is shown for capacitor type PEH200OO427AM, with ambient temperature of 85°C .

The negative foil is in direct contact with the aluminium case and it is a very good heat conductor. This also means that the aluminium case is the same as the negative, but it should not be used as a connection.

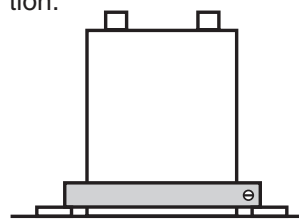

Clip mounted: $R_{th} = 3.6^\circ\text{C}/\text{W}$

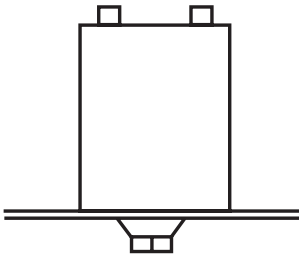

Stud mounted: $R_{th} = 2.1^{\circ}\text{C/W}$

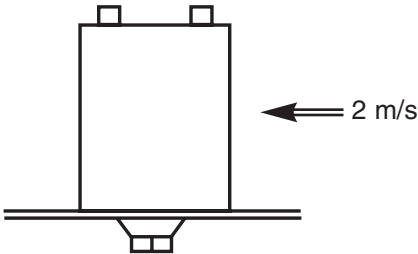

Stud mounted: $R_{th} = 1.8^{\circ}\text{C/W}$

A correct mounting is necessary if the specified operational life time is to be fulfilled. PEH169 and PEH200 should be mounted upright or inclined down to a horizontal position. The safety vent should be upwards. At a failure, hot conductive electrolyte and vapour can come out from the safety vent, so observe the direction of the vent.

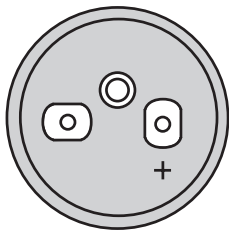

Recommended

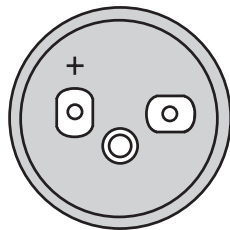

Not recommended

Having stud mounting with good cooling on a chassis is preferable. When the capacitors are clip mounted there can be an air gap between the capacitor and the heat sink.

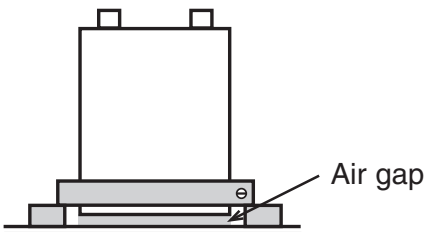

It is much easier to stud mount the capacitor compared with clip mounting. Stud mounting with a nylon cap nut gives an isolation voltage of 2.5 to 4 kV depending on the nut. When capacitors are mounted close together, it is important to have a minimum distance of 5 mm between the capacitors in order to have an acceptable air circulation.

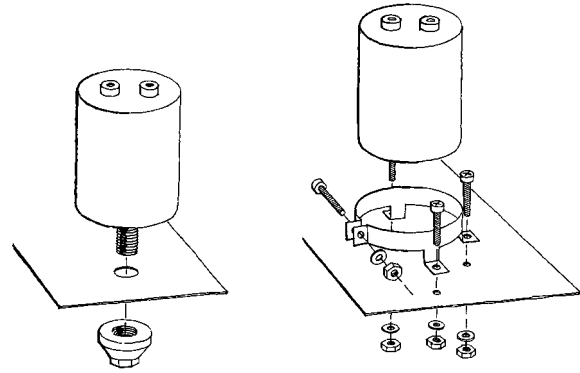

It is important to have the right torque for the screw terminal. If the screws are too loose, there can be a bad connection. If the screws are over tightened, there is a risk the thread will be destroyed. The capacitors can't be mounted hanging in the screw terminals as the lid will break.

PEG's and PEH 430 may be mounted in any position, no accessories are needed.

The PEG type should not be squeezed with a plastic strip on the body, this may cause leakage of electrolyte. At applications with high frequencies, the lead should be as short as possible to minimise the inductance and the skin effect. The mounting shown below to the left is not to be recommended. The mounting shown to the right is the preferred.



The PEG should not be mounted near any warm component. High temperatures will shorten the life time and the capacitor can be the limiting part of the construction.

For applications with high vibration, as in the automotive industry, the PEG126 is recommended.

4 Series and parallel connections

When using series connection it is important to know the voltage across each capacitor. The tolerances of a capacitor can give a very high voltage on one capacitor while the others are applied to lower voltage. Two 350 V capacitors with tolerances $\pm 20\%$ are connected in series and over the two capacitors a voltage of 700 V is applied. In the worst case, one capacitor has max. capacitance and the other has min. capacitance. The capacitor with min. value will be exposed for:

$$U_{cap} = \frac{U_{applied} \times \text{Tolerance}_{max}}{\text{Tolerance}_{max} + (n-1) \times \text{Tolerance}_{min}}$$

$$= \frac{700 \times 1.2}{1.2 + 0.8} = 420 \text{ VDC}$$

n = No. of capacitors in series

To obtain correct voltage sharing between the capacitors, it is a good idea to use voltage sharing resistors. The voltage sharing resistor is calculated:

$$R_{vsr} = \frac{1000}{0.015 \times C [\mu F]} [k\Omega]$$

Example: $C = 4700 \mu F$
 $R_{vsr} = 14 k\Omega$

It is important to have a high quality resistor. If the resistor fails, the capacitors will break down. For high reliability the generated power in the resistor should be less than 50% of the rated value. The tolerances of the two resistors should be better or equal to $\pm 5\%$. Don't forget the time constant τ , it takes some time before the voltage is shared. There are two ways to connect the voltage sharing resistor.

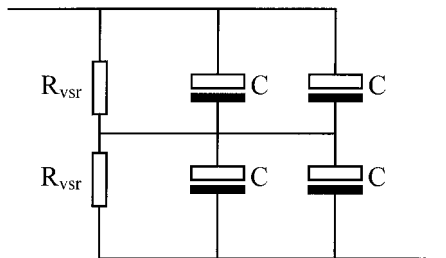
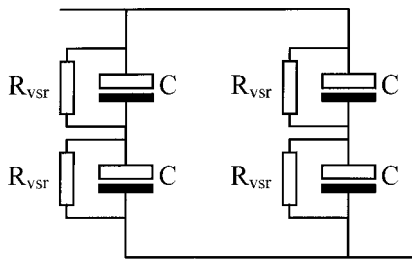

In high current applications it may be necessary to use a parallel connection. Be sure the current distribution is equal in all capacitor branches. At high frequencies, inductances can give different current distribution, as in the first illustration. In the second illustration, the distribution is equal to all capacitors.

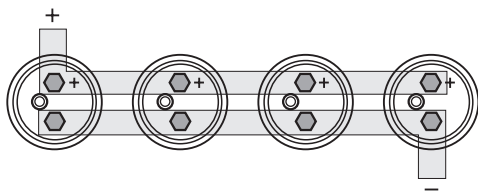
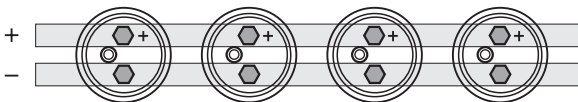

Low inductance bus bars can be built to reduce the inductance, down to less than a nH. In principle the negative side must cover the positive side.

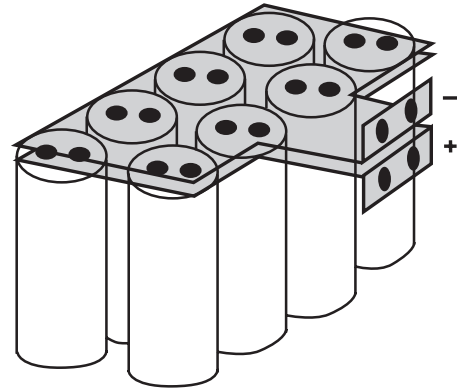

5 Calculate operational life time

To calculate the operational life time (L_{OP}) you have to know the applied voltage ($U_{applied}$), the current through the capacitor (I_{RMS}), ambient temperature (T_a) and thermal resistance (R_{th}).

$$P_{LOSS} = I_{RMS}^2 \times ESR$$

$$T_h = T_a + P_{LOSS} \times R_{th}$$

$$L_{OP} = f(T_h)$$

ESR and R_{th} -matrix is available on request. Please contact Evox Rifa sales representative.

First find the ESR value for the right frequency and hot-spot temperature (T_h) in the ESR matrix. Calculate the power loss (P_{LOSS}). If the current consists of main frequency and different harmonics, calculate the power loss for each harmonic and add up. The thermal resistance between the winding hot spot and the ambient will be found in the R_{th} matrix. Calculate T_h and check if it agrees with the assumption when the ESR was chosen. If not take the new ESR value and make a new calculation. If T_h is known it is easy to calculate L_{OP} .

$$L_{OP} = A \times \frac{85 - T_h}{C}$$

Values for parameter A and C, is given in our catalogue.

The ESR value for electrolytic capacitors depends on the temperature and frequency. Often a value at 20°C and 100 Hz is given.

With the ESR matrix it is possible to calculate the value at other temperatures and frequencies.

ESR matrix

Article number PEH200UV4680MB2

Equivalent series resistance factor k as a function of frequency and winding hot-spot temperature.

$k = \text{ESR}(T_h, f) / \text{ESR}(20^\circ\text{C}, 100\text{Hz})$

$\text{ESR}(20^\circ\text{C}, 100\text{Hz}) = 15 \text{ m}\Omega$ (Maximum value)

11 m Ω (Typical value)

Freq. f kHz	Hot-spot temperature T_h ($^\circ\text{C}$)									
	-40	-20	0	20	40	50	60	70	85	100
0.05	11.6	4.4	2.0	1.4	1.4	1.4	1.5	1.5	1.6	1.7
0.10	11.2	4.0	1.6	1.0	0.92	0.92	0.93	0.95	0.99	1.0
0.15	11.0	3.8	1.4	0.86	0.75	0.75	0.75	0.76	0.79	0.82
0.30	10.9	3.7	1.3	0.71	0.59	0.58	0.57	0.57	0.59	0.61
0.40	10.9	3.6	1.3	0.68	0.55	0.54	0.53	0.53	0.54	0.56
0.60	10.8	3.6	1.2	0.64	0.51	0.49	0.48	0.48	0.49	0.50
0.80	10.8	3.6	1.2	0.62	0.49	0.47	0.46	0.46	0.46	0.48
1.00	10.8	3.6	1.2	0.61	0.48	0.46	0.45	0.44	0.45	0.46
2.00	10.8	3.6	1.2	0.59	0.45	0.43	0.42	0.42	0.42	0.43
5.00	10.8	3.5	1.2	0.58	0.44	0.42	0.40	0.40	0.40	0.41

Example:

Find the ESR value for Hot-spot temperature 70°C and frequency 800 Hz.

Follow the row 0.80 kHz to the column 70°C .

The factor will be 0.46. Multiply the ESR value with factor.

$\text{ESR}(70^\circ\text{C}, 800 \text{ Hz}) = 15 \times 0.46 = 6.9 \text{ m}\Omega$

(Maximum value)

$11 \times 0.46 = 5.1 \text{ m}\Omega$

(Typical value)

The R_{th} value for electrolytic capacitors depends on the ambient temperature, the case temperature, the R_{th} value of the heat-sink (if there is a heat-sink), and the air velocity around the capacitor. If there is no forced air, assume the air velocity to be 0.5 m/s.

R_{th} matrix

Article number PEH200UV4680MB2

Thermal resistance value as a function of case temperature, T_c , and air speed, v , at ambient temperature $T_a = 50^\circ\text{C}$

$R_{th\text{-chassis}} = ^\circ\text{C/W}$

R_{th} : thermal resistance between winding hot spot and ambient

R_{thca} : thermal resistance between case and ambient

T_c $^\circ\text{C}$	$v=0.5\text{m/s}$		$v=1.0\text{m/s}$		$v=1.5\text{m/s}$		$v=2.0\text{m/s}$		$v=2.5\text{m/s}$	
	R_{thca} $^\circ\text{C/W}$	R_{th} $^\circ\text{C/W}$	R_{thca} $^\circ\text{C/W}$	R_{th} $^\circ\text{C/W}$	R_{thca} $^\circ\text{C/W}$	R_{th} $^\circ\text{C/W}$	R_{thca} $^\circ\text{C/W}$	R_{th} $^\circ\text{C/W}$	R_{thca} $^\circ\text{C/W}$	R_{th} $^\circ\text{C/W}$
55	2.9	3.5	2.6	3.1	2.3	2.8	2.1	2.6	2.0	2.5
60	2.9	3.4	2.6	3.1	2.3	2.8	2.1	2.6	2.0	2.5
70	2.9	3.4	2.5	3.0	2.3	2.8	2.1	2.6	1.9	2.5
80	2.9	3.4	2.5	3.0	2.2	2.8	2.1	2.6	1.9	2.5

Example:

Find the R_{th} value for ambient temperature 50°C , case temperature 70°C and air velocity 1.5 m/s.

Follow the row 70°C to the column 1.5 m/s. R_{thca} will be 2.3°C and R_{th} 2.8°C .

End of life of a capacitor is defined with the following points

- $\Delta C / C = \pm 15\%$ for $U_R \leq 160 \text{ VDC}$
 $\Delta C / C = \pm 10\%$ for $U_R > 160 \text{ VDC}$
- $\tan \delta \leq 1.3 \times \text{specified value}$
- $I_L < I_{RL}$
- $\text{ESR} \leq 2 \times \text{ESR initial value}$

Leakage current, I_L , is a direct result of the quality of the dielectric.

The failure rate is given in the catalogue and it is derived from test results.

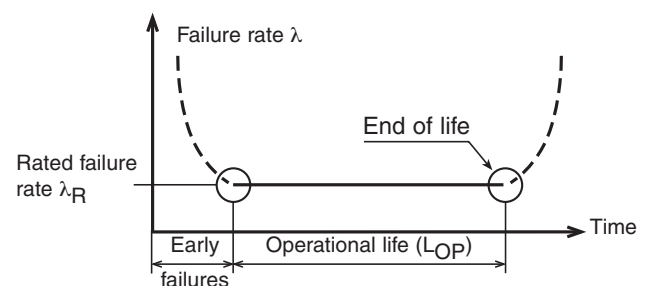

6 Avoid destroying the capacitor

Capacitors can be destroyed if they are exposed to over voltage, for example transients. On the mains there are a lot of transients, it is not a pure sine wave.

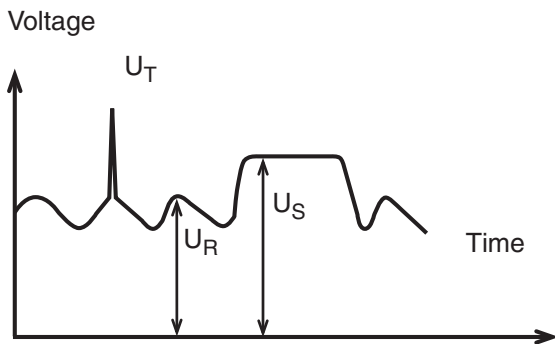
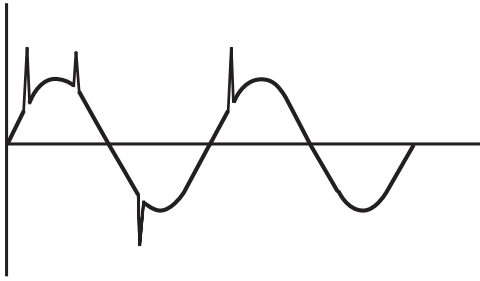

- U_R Rated voltage
- U_S Surge voltage 1000 cycles with load period 30 sec and no load period 330 sec
- U_T Transient voltage.

The over voltage can also occur when the capacitors are connected to a LC-filter.

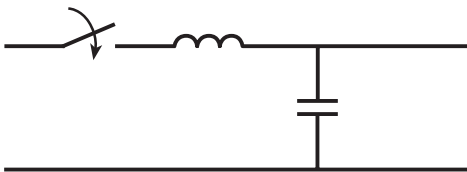

The voltage over the capacitor will have an over shot.

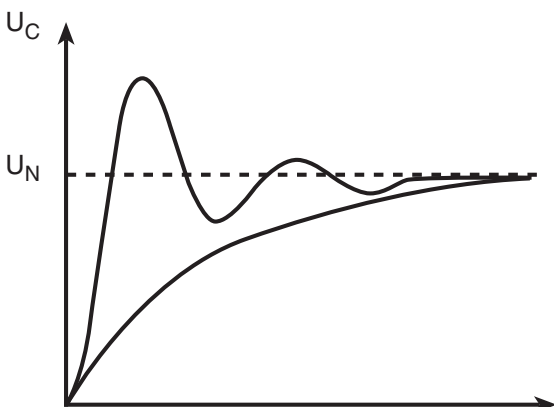

To avoid high voltage when connecting the capacitors to voltage it is good to use a soft start. The switch is a semi conductor.

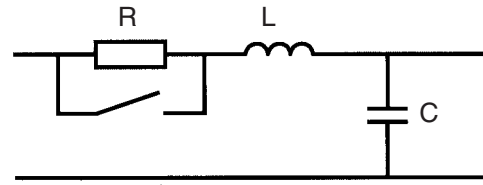

A filter before the rectifier stops some fast transients but not all.

If the capacitor is connected to the wrong polarisation it will damage the capacitor very quickly. To avoid wrong polarisation the connections are turned 90°, i.e. Poka Yoka.

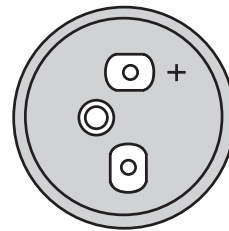

If the current exceeds the rated current it will shorten the life time. Shorter periods of excessive ripple current is okay as long as it's a short duration compared to the thermal time constant, τ . The life time depends on the hot spot temperature. With a temperature sensor or a temperature strip it is possible to measure the temperature rise in the capacitor. The temperature

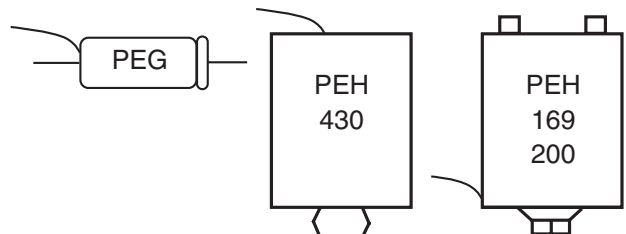

should be measured directly on the aluminium. For PEH169 and 200 it is possible to measure the hot spot temperature with thermo couple inside the capacitor.

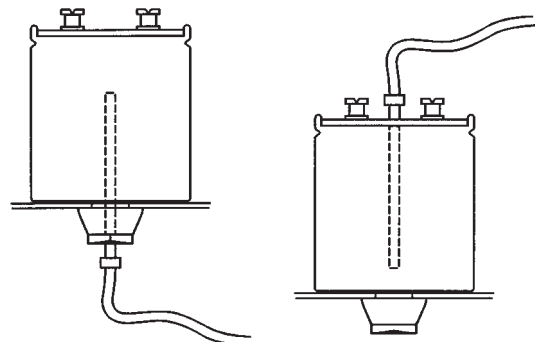

7 Intermittent operation PEG126

It is not always relevant to specify an application for continues operation. We are using the following thermal model for intermittent calculations:

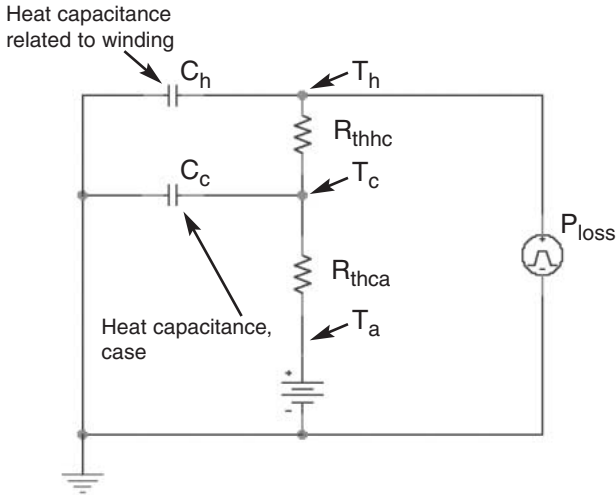

The model includes the thermal resistance internally in the capacitor (R_{thhc}) and externally between case and ambient (R_{thca}). The heat capacitance for the capacitor winding and case is also needed in this dynamic model.

Example:

The thermal parameters and ESR- matrix is available on request,

E.g. PEG126KL427BM:

$$R_{thhc} = 7.7 \text{ } ^\circ\text{C/W}$$

$$R_{thca} = 18 \text{ } ^\circ\text{C/W (without forced air cooling)}$$

Winding:

$$C_h = 21 \text{ J/}^\circ\text{C}$$

Case:

$$C_c = 2.5 \text{ J/}^\circ\text{C}$$

Ripple current:

On : 20A, 5kHz during 5 minutes,

Off: No current during 15 minutes

(period time: 20 minutes)

Ambient temperature: 93°C

No forced air cooling.

ESR=8.7 mΩ

Power loss: $I_{RMS}^2 \times \text{ESR} = 3.5\text{W}$ (during “on”)

See even chapter 5.

When the thermal parameters is specified and the power loss is calculated, the hot-spot and case temperature can be calculated by computer simulation.

(E.g. PSpice. Transform power loss to DC-current and temperatures to voltages):

Hotspot- (T_h) and case temperature (T_c), computer simulation:

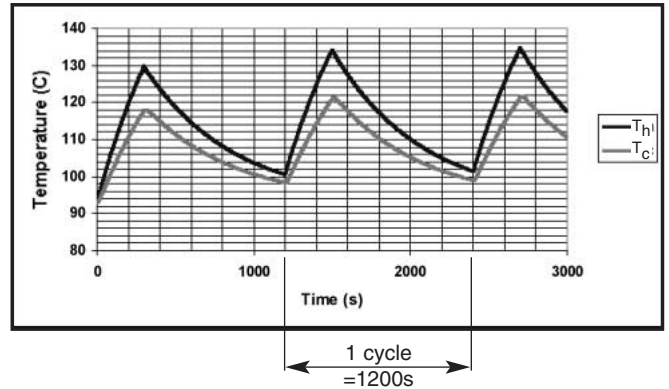

Specification limits, intermittent operation:

- Up to 95% increased ripple current, compared with specified values at continues operation (at max 25% intermittence)
- Max ripple current, can be applied, at hot-spot temperature (T_h) up to 135°C
- Max ripple current, during 100h, at $T_h \leq 45 \text{ } ^\circ\text{C}$

Life time calculation:

The life time calculation described in chapter 5, is based on the electrolyte diffusion during continues operation. The diffusion rate is inversely proportional to the calculated L_{OP} . Operational life time calculation, at intermittent operation, is than carried out by numeric integration over one temperature cycle:

Operational life (L_{OP}) - numerical integration:

$$L_{OP} = 1 / (\text{mean} [1 / L_{OP}''(t)])$$

$$\text{where } \text{mean} [1 / L_{OP}''(t)] = 1 / (\Delta t \times A) \times \int 1 / [2^{((85 - T_h)/C)}] dt =$$

(integration over 1 temp. cycle
 $\Delta t = 1 \text{ cycle}$)

L_{OP} for the example above: $A=97\text{kh}$, $C=11$, T_h in accordance with diagram. Numerical integration $\Rightarrow L_{OP}=12\text{kh}$. Max $T_h=135^\circ\text{C}$ (OK in accordance to spec. limits.)

8 Calculation examples

The electrolytic capacitor is often used to smooth the voltage after a rectifier.

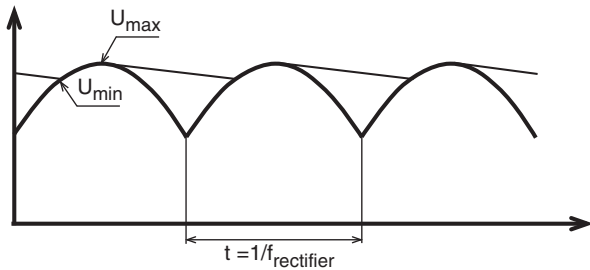

Needed capacitance to manage a certain level of ripple voltage is

$$C_{\min} = \frac{2 \times P}{(U_{\max}^2 - U_{\min}^2) \times f_{\text{rectifier}}}$$

P is the power load in watts.

Remember that this is the minimum required capacitance. It is important to remember the tolerances of the capacitor. During the life time the capacitance will decrease and it will also decrease with low temperatures.

The ripple current from the main and from the load has to be known. First calculate the capacitor voltage charge time.

$$t_c = \frac{\arccos\left(\frac{U_{\min}}{U_{\max}}\right)}{2 \times \pi \times f_{\text{main}}}$$

f_{main} is the frequency from the main.

Now it is possible to calculate the capacitor voltage discharge time.

$$t_{\text{DC}} = \frac{1}{f_{\text{rectifier}}} - t_c$$

The peak value of the charge current I_C is

$$I_{C\text{peak}} = C \times \frac{dU}{dt_c}$$

dU is the voltage ripple ($U_{\max} - U_{\min}$).

$$I_{\text{CRMS}} = \sqrt{I_{C\text{peak}}^2 \times t_c \times f_{\text{rectifier}}}$$

Next the peak and RMS. discharge current can be calculated.

$$I_{\text{DCpeak}} = C \times \frac{dU}{dt_{\text{DC}}}$$

$$I_{\text{DCRMS}} = \sqrt{I_{\text{DCpeak}}^2 \times t_{\text{DC}} \times f_{\text{rectifier}}}$$

Now the ripple current resulting from the rectification of the AC line can be made.

$$I_{\text{RMS}} = \sqrt{I_{\text{CRMS}}^2 + I_{\text{DCRMS}}^2}$$

Drives

Continuous voltage:	750 VDC
Ripple currents:	60 A @ 4 kHz
	75 A @ 8 kHz
	50 A @ 12 kHz
	30 A @ 16 kHz
	20 A @ 32 kHz
Required capacitance:	7000 μF
Tolerance:	-10 to + 30%
Life time:	70 000 hours
Maximum ambient temperature:	70°C
Forced air:	2 m/s
Heat sink:	1.0°C/W

To handle the voltage 750 VDC it is necessary to have two capacitors in series. But the tolerances of the capacitors have to be taken into consideration. If the tolerance is $\pm 20\%$, the worst case gives:

$$U_{\max} = 750 \times \frac{1.2}{1.2 + 0.8} = 450 \text{ VDC}$$

Use a 450 V capacitor. If a 4700 μF capacitor is chosen there must be three branches to fulfil the capacitance requirement. PEH200YV447DQB2 is a good selection.

First calculate the ESR values, assume hot-spot temperature to 85°C.

$$\text{ESR}(85^\circ\text{C}, 4 \text{ kHz}) = 13 \times 0.31 = 4.0 \text{ m}\Omega$$

$$\text{ESR}(85^\circ\text{C}, 8 \text{ kHz}) = 13 \times 0.30 = 3.9 \text{ m}\Omega$$

$$\text{ESR}(85^\circ\text{C}, 12 \text{ kHz}) = 13 \times 0.29 = 3.8 \text{ m}\Omega$$

$$\text{ESR}(85^\circ\text{C}, 16 \text{ kHz}) = 13 \times 0.29 = 3.8 \text{ m}\Omega$$

$$\text{ESR}(85^\circ\text{C}, 32 \text{ kHz}) = 13 \times 0.29 = 3.8 \text{ m}\Omega$$

Calculate the power loss in each capacitor, we have three branches, the capacitor current is a third of the total current.

$$\begin{aligned} P_{\text{LOSS}} &= \text{ESR}_1 \times I_{\text{RMS1}}^2 + \text{ESR}_2 \times I_{\text{RMS2}}^2 + \text{ESR}_3 \times \\ &I_{\text{RMS3}}^2 + \text{ESR}_4 \times I_{\text{RMS4}}^2 + \text{ESR}_5 \times I_{\text{RMS5}}^2 = \\ &0.0040 \times 20.0^2 + 0.0039 \times 25.0^2 + 0.0038 \\ &\times 16.7^2 + 0.0038 \times 10.0^2 + 0.0038 \times 6.67^2 \\ &= 5.64 \text{ W} \end{aligned}$$

Now it is possible to calculate the hot-spot temperature. The thermal resistance comes from the R_{th} -matrix, thermal resistance of the heat sink is 1.0°C/W and air velocity 2 m/s.

$$T_h = T_a + P_{\text{LOSS}} \times R_{\text{th}} = 70 + 5.64 \times 1.5 = 78.5^\circ\text{C}$$

The assumption of the hot-spot temperature was 85°C. But for this type of capacitor the ESR doesn't differ very much at this temperature so there is no need to calculate a new value.

The hot-spot temperature gives the operational life time. PEH200 450 VDC and diameter 75 mm has following L_{OP} equation.

$$L_{OP} = 40000 \times 2^{\frac{85-T_h}{12}} = 40000 \times 2^{\frac{85-78.5}{12}} = 58.2 \text{ khours}$$

This solution is far below the specification. It is necessary with four branches.

$$P_{LOSS} = ESR_1 \times I_{RMS1}^2 + ESR_2 \times I_{RMS2}^2 + ESR_3 \times I_{RMS3}^2 + ESR_4 \times I_{RMS4}^2 + ESR_5 \times I_{RMS5}^2 = 0.0040 \times 15.0^2 + 0.0039 \times 18.8^2 + 0.0038 \times 12.5^2 + 0.0038 \times 7.5^2 + 0.0038 \times 5.0^2 = 3.17 \text{ W}$$

$$T_h = T_a + P_{LOSS} \times R_{th} = 70 + 3.17 \times 1.5 = 74.8^\circ\text{C}$$

$$L_{OP} = 40000 \times 2^{\frac{85-T_h}{12}} = 40000 \times 2^{\frac{85-74.8}{12}} = 72.1 \text{ khours}$$

The failure rate per hour is about 5.0×10^{-7} . $R(t)$ is the number of capacitors working.

$$R(t) = n \times e^{(-\lambda \times t)} \quad \lambda = \text{failure rate}$$

t = time in hours n = number of used capacitors

Assume 80 000 capacitors are used. How many will still work at 57 000 hours?

$$R(57000h) = 80000 \times e^{-5.0 \times 10^{-7} \times 57000} = 77750$$

That means 2250 capacitors have failed i.e. 2,8% of the total number.

Electronic Ballast

Applied voltage:	420 VDC
Ripple currents:	130 mA @ 100 Hz 210 mA @ 25 kHz 150 mA @ 50 kHz 30 mA @ 75 kHz
Required capacitance:	22 μF
Tolerance:	-10 to + 30%
Life time:	50 000 hours
Maximum ambient temperature:	90°C

The capacitor PEG124YH2220Q (450 VDC / 22 μF) seems to match the requirements.

First calculate the ESR values, assume hot-spot temperature to 100°C.

$$\begin{aligned} ESR(100^\circ\text{C}, 100 \text{ Hz}) &= 2.366 \times 0.94 = 2.22 \Omega \\ ESR(100^\circ\text{C}, 25 \text{ kHz}) &= 2.366 \times 0.15 = 0.35 \Omega \\ ESR(100^\circ\text{C}, 50 \text{ kHz}) &= 2.366 \times 0.15 = 0.35 \Omega \\ ESR(100^\circ\text{C}, 75 \text{ kHz}) &= 2.366 \times 0.15 = 0.35 \Omega \end{aligned}$$

Calculate the power loss in the capacitor.

$$P_{LOSS} = ESR_1 \times I_{RMS1}^2 + ESR_2 \times I_{RMS2}^2 + ESR_3 \times I_{RMS3}^2 + ESR_4 \times I_{RMS4}^2 = 2.22 \times 0.130^2 + 0.35 \times 0.210^2 + 0.35 \times 0.150^2 + 0.35 \times 0.03^2 = 61 \text{ mW}$$

Now it is possible to calculate the hot-spot temperature. The thermal resistance comes from the R_{th} -matrix, assume natural air convection (0.5 m/s).

$$T_h = T_a + P_{LOSS} \times R_{th} = 90 + 0.061 \times 26.2 = 91.6^\circ\text{C}$$

The assumption of the hot-spot temperature was 100°C. There is no significant difference between ESR (92°C) and ESR (100°C). Recalculation is not needed.

The hot-spot temperature gives the operational life time. PEG124 450 VDC and diameter 20 mm has following L_{OP} equation. L_{OP} in thousand hours.

$$L_{OP} = 97 \times 2^{\frac{85-T_h}{11}} = 97 \times 2^{\frac{85-91.6}{11}} = 64 \text{ khours}$$

This capacitor fulfil the life time requirements.

The failure rate per hour is about 4.0×10^{-7} . $R(t)$ is the number of capacitors working.

$$R(t) = n \times e^{(-\lambda \times t)} \quad \lambda = \text{failure rate}$$

t = time in hours n = number of used capacitors

Assume 500 000 capacitors are used. How many will still work at 50 000 hours?

$$R(50000h) = 500000 \times e^{-4.0 \times 10^{-7} \times 50000} = 490000$$

That means that 1000 capacitors have failed i.e. 2% of the total number.

Welding

Continuous voltage:	430 VDC
Ripple currents:	15 A @ 100 Hz 9 A @ 50 kHz
Required capacitance:	1000 μF
Tolerance:	$\pm 20\%$
Life time:	10 000 hours
Maximum ambient temperature:	60°C
Forced air:	1 m/s
Snap-in terminals	

Use a 450 VDC capacitor. To handle the ripple currents three 330 μF capacitors, PEH430YT3330M2, are used in parallel.

The ESR values are at hot-spot temperature 70°C
 ESR (70°C, 100 Hz) = 188 x 0.8 = 150 mΩ
 ESR (70°C, 50 kHz) = 188 x 0.15 = 28 mΩ

Calculate the power loss in each capacitor, we have three branches, the capacitor current is a third of the total current.

$$P_{\text{LOSS}} = \text{ESR}_1 \times I_{\text{RMS1}}^2 + \text{ESR}_2 \times I_{\text{RMS2}}^2 = 0.150 \times 5.0^2 + 0.028 \times 3.0^2 = 4.0 \text{ W}$$

Calculate the hot-spot temperature. The thermal resistance comes from the R_{th} -matrix, air velocity 1 m/s.

$$T_h = T_a + P_{\text{LOSS}} \times R_{\text{th}} = 60 + 4.0 \times 10.7 = 103^\circ\text{C}$$

It is necessary with four branches. Try with PEH430YT3330M2.

$$L_{\text{OP}} = 13000 \times 2^{\frac{85-T_h}{12}} = 13000 \times 2^{\frac{85-103}{12}} = 4.6 \text{ khours}$$

This solution doesn't fulfil the requirement of the life time. It is necessary to use more branches or larger capacitors. Forced air is another alternative to reach 10 khours lifetime.

Automotive

Applied voltage: 14 VDC
 Ripple currents: 3 A @ 20 kHz
 Required capacitance: 600 μF
 Tolerance: -10 to + 30%
 Life time: 2000 hours
 Maximum ambient temperature: 130°C

Because it is an automotive application it has a high vibration and PEG126 is preferable. We start with PEG126KG360EQL1.

The ESR value is for 140°C and 20 kHz = 0.116 x 0.09 = 11 mΩ

The power loss in the capacitor will be:

$$P_{\text{LOSS}} = \text{ESR} \times I_{\text{RMS}}^2 = 0.0104 \times 3^2 = 94 \text{ mW}$$

Assume no air flow. The thermal resistance will be 34.3°C/W.

$$T_h = T_a + P_{\text{LOSS}} \times R_{\text{th}} = 130 + 0.094 \times 34.3 = 133^\circ\text{C}$$

The L_{OP} equation for PEG126 (Ø 16 mm) is:

$$L_{\text{OP}} = 64\text{k} \times 2^{\frac{85-T_h}{12}} = 64\text{k} \times 2^{\frac{85-133}{12}} = 4.0 \text{ khours}$$

The capacitor fulfil the requirements.

Uninterruptable Power Supply (UPS)

Continuous voltage: 565 VDC
 Ripple currents: 15 A @ 300 Hz
 27 A @ 20 kHz
 Required capacitance: 1000 μF
 Tolerance: -10 to + 30%
 Life time: 22 000 hours
 Maximum ambient temperature: 60°C

350 VDC capacitors are used. If two 680 μF capacitors are connected in series, it is necessary to have three branches, for example PEH200UG3680M.

The L_{OP} calculation for PEH200 size 50 x49 mm is

$$L_{\text{OP}} = 24000 \times 2^{\frac{85-T_h}{12}}$$

If the life should be 22 000 hours, maximum hot-spot temperature is

$$T_h = 85 - 12 \times \frac{\ln\left(\frac{L_{\text{OP}}}{24000}\right)}{\ln 2} = 85 - 12 \times \frac{\ln\left(\frac{22000}{24000}\right)}{\ln 2} = 86.5^\circ\text{C}$$

ESR(81°C, 300 Hz) = 0.46 x 0.130 = 60 mΩ
 ESR(81°C, 20 kHz) = 0.23 x 0.130 = 30 mΩ

The power loss is

$$P_{\text{LOSS}} = \text{ESR}_1 \times I_{\text{RMS1}}^2 + \text{ESR}_2 \times I_{\text{RMS2}}^2 = 0.060 \times (15/3)^2 + 0.030 \times (27/3)^2 = 3.9 \text{ W}$$

There are three branches, that is why the currents are divided by three.

Thermal resistance is 6.7°C/W.

$$T_h = T_a + P_{\text{LOSS}} \times R_{\text{th}} = 60 + 3.9 \times 6.7 = 86^\circ\text{C}$$

L_{OP} calculation is

$$L_{\text{OP}} = 24000 \times 2^{\frac{85-T_h}{12}} = 24000 \times 2^{\frac{85-86}{12}} = 25000$$

The capacitors fulfil the requirement.

Valve amplifier

DC voltage:	360 VDC
Maximum voltage:	361 VDC
Minimum voltage:	359 VDC
Load current:	250 mA @ 100 Hz

The load power is $P_{load} = U \times I = 360 \times 0.25 = 90 \text{ W}$

Needed capacitance is

$$C_{min} = \frac{2 \times P}{(U_{max}^2 - U_{min}^2) \times f} = \frac{2 \times 90}{(361^2 - 359^2) \times 100} = 0.00125 \text{ F} = 1250 \mu\text{F}$$

When the main transformer is unloaded the output can be up to 10% higher. The main power can also increase by 10%. Then the voltage rating of the capacitor must be $360 \times 1.1 \times 1.1 = 436 \text{ VDC}$. Use a 450 VDC capacitor. PEH200YL4150M is a good selection, rated capacitance is 1500 μF . ESR is less than 43 m Ω at 20°C.

Start to calculate the charge time:

$$t_C = \frac{\arccos\left(\frac{U_{min}}{U_{max}}\right)}{2 \times \pi \times f_{main}} = \frac{\arccos\left(\frac{359}{361}\right)}{2 \times \pi \times 50} = 335 \mu\text{s}$$

Discharge time is

$$t_{DC} = \frac{1}{f_{rectifier}} - t_C = \frac{1}{100} - 335 \times 10^{-6} = 9665 \mu\text{s}$$

The peak value of the charge current is

$$I_{Cpeak} = C \times \frac{dU}{dt_C} = 1500 \times 10^{-6} \times \frac{2}{335 \times 10^{-6}} = 8.9 \text{ A}$$

$$I_{CRMS} = \sqrt{I_{Cpeak}^2 \times t_C \times f_{rectifier}} = \sqrt{8.9^2 \times 335 \times 10^{-6} \times 100} = 1.6 \text{ A}$$

The peak value of the discharge current is

$$I_{DCpeak} = C \times \frac{dU}{dt_{DC}} = 1500 \times 10^{-6} \times \frac{2}{9665 \times 10^{-6}} = 0.31 \text{ A}$$

$$I_{DCRMS} = \sqrt{I_{DCpeak}^2 \times t_{DC} \times f_{rectifier}} = \sqrt{0.31^2 \times 9665 \times 10^{-6} \times 100} = 0.31 \text{ A}$$

$$I_{RMS} = \sqrt{I_{CRMS}^2 \times I_{DCRMS}^2} = \sqrt{1.6^2 + 0.31^2} = 1.7 \text{ A}$$

$$P_{LOSS} = \text{ESR} \times I_{RMS}^2 = 0.043 \times 1.7^2 = 0.12 \text{ W}$$

In this case the power loss in the capacitor only causes a minor temperature rise above the ambient temperature. $T_h \approx T_a$.

9 Operational life time equations

Life time calculation of Rifa electrolytic capacitors

$$P_{LOSS} = I_{RMS}^2 \times \text{ESR} \quad T_h = T_a + P_{LOSS} \times R_{th} \quad T_h - T_a \leq 30^\circ\text{C}$$

P_{LOSS} = Power loss in the capacitor
 T_h = Hot-spot temperature
 I_{RMS} = Ripple current
 T_a = Ambient temperature
 ESR = Equivalent series resistance
 R_{th} = Thermal resistance

$$L_{OP} = \text{Expected life time} = A \times 2 \frac{85 - T_h}{C} \text{ hours}$$

Calculation example (PEH 2000O427AMB2)

Input: Ambient temperature = 70°C
 Ripple current = 30 A (10 kHz)
 $U_{applied} = 350 \text{ V}$
 ESR (85°C, 10 kHz) = 4.6 m Ω
 Thermal resistance $R_{th} = 4.3 \text{ }^\circ\text{C/W}$

Calculation: $P_{LOSS} = I_{RMS}^2 \times \text{ESR} = 30^2 \times 4.6 \times 10^{-3} = 4.1 \text{ W}$
 Hot spot temp $T_h = T_a + R_{th} \times P_{LOSS} = 70 + 4.3 \times 4.1 = 88^\circ\text{C}$
 The assumption of hot-spot temp 85°C was OK!
 (There is no significant difference between ESR (88°C) and ESR (85°C)).

Output: Expected Life time $L_{OP} = 30000 \times 2 (85 - T_h) = 30000 \times 2 \frac{85 - 88}{12} = 25 \text{ khours}$

R_{th} and ESR matrixes are available on request. Please contact Evox Rifa sales representative.

10 www.evovx-rifa.com

On our homepage you can download our CAD application software that automatically calculates the optimum solutions for your power electronics application.

Solution optimized on price, number, bottom area, volume or weight

Req. Capacitance uF

Voltage V

Air velocity m/s

Mounting
 Clip
 Stud

Heat-sink
 Yes
 No

Capacitor type

- PEH169 85 deg C
- PEH169 105 deg C
- PEH200 85 deg C

Optimization

- Price
- Number of components
- Bottom area
- Volume
- Weight
- Total power dissipation

ESR calculation

- Max
- Mean

Total Irms 1,0 A **Freq. range** 2,000 - 2,000 kHz

Total Lop 10 kh **Mean ambient temperature** 60,0 °C