

PHG491

• Power electronic capacitor, metallized polypropylene

TYPICAL APPLICATIONS

The PHG491 capacitor is intended for use in power electronic equipment, for example GTO snubber application. The capacitor is capable of operating continuously under non-sinusoidal current or voltage.

CONSTRUCTION

The PHG491 is a range of metallized polypropylene capacitors with low series resistance and low thermal resistance. Together with the special choice of metallized layer this gives a high ability to withstand voltage and current.

TECHNICAL DATA

Rated voltage, VDC	1200	1600	2000
Pulse rise time, dU/dt , V/ μ s, up to	1125	1125	1125
Capacitance range, μ F	0.5 – 10	0.22 – 6	0.5 – 4
Capacitance tolerance	$\pm 5\%$		
Climatic category	40/085/56		
Temperature range	– 40°C to + 85°C		
Insulation resistance	Between terminals 3×10^4 s.		
Hot Spot temperature, Th	$\leq + 85^\circ\text{C}$.		

Quality and test data

All capacitors are subjected to 100% screening inspection in respect of voltage between terminals, capacitance, dissipation factor (1 kHz and 10 kHz) and insulation resistance between terminals. Each lot is sampled to establish the function of the screening inspection. The product quality is continuously followed by periodic tests, where the data of the product specification are established to be kept in the current production.

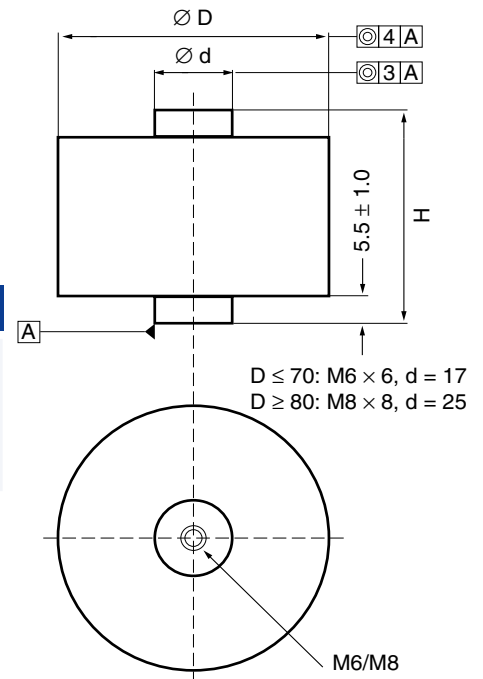

MOUNTING

The capacitors can be mounted in any position. Max tightening torque:
M6 = 6 Nm
M8 = 10 Nm

ENVIRONMENTAL TEST DATA

Test	IEC Publication	Procedure	Requirements
Voltage proof	60384-1, clause 4.6		No flashover or permanent breakdown
Type test: between terminals		10 s 1700 VDC ($U_{DC} = 1200$ V) 2200 VDC ($U_{DC} = 1600$ V) 2700 VDC ($U_{DC} = 2000$ V)	
Routine test: between terminals		2 s 1700 VDC ($U_{DC} = 1200$ V) 2200 VDC ($U_{DC} = 1600$ V) 2700 VDC ($U_{DC} = 2000$ V)	
Insulation resistance between terminals	60384-1, clause 4.5	Measured at 500 VDC after 60 s, $T_{amb} 23^\circ\text{C}$	3×10^4 s
Dissipation factor	60384-1, clause 4.8	1 kHz, 10 kHz	$\leq 3 \times 10^{-4}$ $\leq 8 \times 10^{-4}$
Damp heat, steady state	60068-2-3 (1969)		56 days
Bump	60068-2-27 test Ea	4000 bumps, 245 m/s ² in any direction	No visible damage No open or short circuit

MARKING

- RIFA
- RIFA article code
- Rated capacitance
- Capacitance tolerance code
- Rated voltage
- U_{RMS} at 50 Hz
- MKP for metallized polypropylene
- Manufacturing code

ARTICLE TABLE

U_s 1500 V (non rep.)
 U_{max} 1200 V (rep.)
 U_{DC} 1200 V
 U_{RMS} 550 VAC, 50 Hz

Rated cap	Dimensions in mm	dU/dt max	dU/dt rep	I ² x t	Dissipation factor ¹⁾	I _{rms} ²⁾	R _s	Inductance	Thermal resistance Hot spot-terminal	Weight	Qty/package	Article code
μF	Δ Dmax x H	V/μS	V/μs	A ² s	K	A	m Ω	nH	R _{THHT} °C/W	g	pcs	
0.5	40 x 49	1125	750	0.45	9	15	3.0	10	18.0	95	64	PHG491LB6500J
1	50 x 49	1125	750	1.8	10	20	1.6	10	10.7	130	49	PHG491LC7100J
2	58 x 49	1125	750	7.2	12	40	1.0	10	6.0	170	36	PHG491LD7200J
3	70 x 49	1125	750	16	14	55	0.7	10	4.2	230	25	PHG491LE7300J
4	80 x 52	1125	750	29	16	70	0.6	10	3.2	350	16	PHG491LG7400J
6	90 x 52	1125	750	65	20	80	0.5	10	2.2	450	16	PHG491LL7600J
8	90 x 62	750	500	77	32	65	0.6	10	3.5	500	16	PHG491LK7800J
10	90 x 62	750	500	120	36	75	0.6	10	2.9	500	16	PHG491LK8100J

U_s 2000 V (non rep.)
 U_{max} 1600 V (rep.)
 U_{DC} 1600 V
 U_{RMS} 650 VAC, 50 Hz

0.22	40 x 49	1125	750	0.1	8	7	3.5	10	20.0	95	64	PHG491NB6220J
0.5	40 x 49	1125	750	0.45	8	15	2.4	10	14.2	95	64	PHG491NB6500J
1	50 x 49	1125	750	1.8	9	25	1.4	10	8.3	130	49	PHG491NC7100J
2	70 x 49	1125	750	7.2	11	50	0.8	10	4.6	230	25	PHG491NE7200J
3	80 x 52	1125	750	16	12	65	0.7	10	3.2	350	16	PHG491NG7300J
4	90 x 52	1125	750	29	14	80	0.6	10	2.4	450	16	PHG491NL7400J
6	90 x 62	750	500	65	25	65	0.7	10	3.4	500	16	PHG491NK7600J

U_s 2500 V (non rep.)
 U_{max} 2000 V (rep.)
 U_{DC} 2000 V
 U_{RMS} 750 VAC, 50 Hz

0.5	50 x 49	1125	750	0.45	6	20	2.0	10	10.8	130	49	PHG491VC6500J
1	58 x 49	1125	750	1.8	7	40	1.1	10	6.1	170	36	PHG491VD7100J
2	70 x 59	750	500	4.8	15	35	1.2	10	6.5	270	25	PHG491VF7200J
2.5	80 x 62	750	500	8.0	16	40	1.0	10	5.5	420	16	PHG491VH7250J
3	80 x 62	750	500	11	17	50	0.9	10	4.7	420	16	PHG491VH7300J
4	90 x 62	750	500	19	18	65	0.7	10	3.7	500	16	PHG491VK7400J

¹⁾ $\tan\delta = 200 \times 10^{-6} + K \times f_{kHz} \times 10^{-6}$

²⁾ Higher current can be used after testing and calculation of the temperature in the Hot-spot.

ORDERING INFORMATION

The article code for the standard part is given in the article table. For other options, see page 21.

MECHANICAL DATA

The capacitor winding is encapsulated in self-extinguishing material meeting the requirements of UL 94V-0. The capacitor has axial screw terminals with inner thread M6 respectively M8.