

UNIVERSAL INPUT HARMONIC CORRECTION AC-DC MULTIPLE OUTPUT 150 WATTS INTERNAL SWITCHING POWER SUPPLIES APS149VP SERIES



FEATURES:

- ACCOMMODATES UNIVERSAL AC SOURCES
- MEETS IEC1000-3-2 HARMONIC CORRECTION
- DUAL CONVERTER ARCHITECTURE
- +5V STAND-BY GREEN POWER
- MEETS UNIVERSAL SAFETY STANDARDS
- EMI MEETS CISPR PUB.22 / FCC CLASS B
- CE MARKING COMPLIANCE

SPECIFICATION

INPUT SPECIFICATION

Input Voltage: Typ. 90-264Vac with PFC.
Input Connector: V-M (Molex 5273) connector.
Input Frequency: 47-63Hz.
Inrush Current: Typ. $\leq 30.6A@230Vac$.
Input Current: 2.0A @115Vac./ 0.96A @230Vac.
Dielectric Withstand: Meet IEC950.
EMI: Meet CISPR PUB.22/FCC Class B.
Hold-up Time: Typ. 20mS @115Vac & 230Vac.
Power Fail Signal: Installed.
DC OK Signal: Installed in two main outputs.
Remote Inhibit: Installed. Enable active low.
Power Factor & Harmonic Correction:
 Meet IEC1000-3-2, PF typ.0.99@ full load.
Over Temperature Protection: By thermostat.
Earth Leakage: Less than 0.75mA.

OUTPUT SPECIFICATION

Output Voltage: See Ratings Chart.
Output Current: See Ratings Chart.
Output Connector: B-S, V-M (Molex 5273), X-H (Molex 5268) connectors.
Output Wattage: Typ. 150W with 30 CFM forced air cooling.
Line Regulation: Typ. 0.1%.
Load Regulation: Main VO1 & Aux. VO2 typ. $\pm 1-1.5\%$.
 Main VO3 & Aux. VO4 typ. $\pm 5.0\%$.
Noise & Ripple: Typ. 1.0% peak to peak.
OVP: Installed in VO1, VO2 & VO3 (Latch).
Remote Sensing: Installed in O/P VO1 & VO2.
Adjustability: Available at VO1, VO2 and VO3.
Load Sharing: Active current sharing circuit available at VO1 & VO2 rail.
Overload Protection (OLP): Fully protected against output overload and short circuit. Consult the factory for the OLP setting.

GENERAL SPECIFICATION

Efficiency: Typ. 70-73.7%.
Switching Frequency: Fixed frequency at 70K Hz.
Circuit Topology: Dual converter architecture.
 1st, forward circuit for VO1 & VO2 rails.
 2nd, fixed-frequency flyback circuit for VO3 & VO4 rails.
Transient Response: Output voltage returns in less than 1mS following a 25% load change.
Safety Standard: UL1950/EN60950 Class I.
Power Density: 3.0 Watts / Cubic Inch.
Operating Temperature: 0 to +50°C under forced air cooling for half load.
Storage Temperature: -55 to +85°C.
Temperature Coefficient: 0 to +70°C (after 15 minutes warm-up) typ. $\pm 0.02-0.05\%/^{\circ}C$.
Cooling: 25-30 CFM airflow is required to deliver the full power. 150W.
Construction: U-bracket construction format.
Industrial Grade.

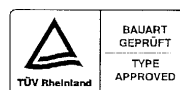

OUTPUT VOLTAGE/CURRENT RATINGS CHART

SINGLE OUTPUT (Under forced air cooling)

MODEL NO.	MAIN VO1 @*#=#	
	Typ.	Volt.
APS149VP-033350	35.00A	+3.3V
APS149VP-050300	30.00A	+5.0V
APS149VP-120150	15.00A	+12.0V
APS149VP-240075	7.50A	+24.0V
APS149VP-480375	3.75A	+48.0V

DUAL OUTPUT (Under forced air cooling)

MODEL NO.	MAIN VO1 @*#=#		AUX. VO2 @*#=#	
	Typ.	Volt.	Typ.	Volt.
APS149VP-20	30A	+5.0V	10A	+5.0V
APS149VP-21	30A	+5.0V	5A	+12.0V
APS149VP-22	30A	+5.0V	5A	+15.0V
APS149VP-23	30A	+5.0V	3A	+24.0V
APS149VP-290A	30A	+5.0V	15A	+3.3V
APS149VP-290B	30A	+3.3V	8A	+5.0V
APS149VP-291	30A	+3.3V	5A	+12.0V
APS149VP-292	30A	+3.3V	4A	+15.0V
APS149VP-293	30A	+3.3V	3A	+24.0V

TRIPLE OUTPUT (Under forced air cooling)

MODEL NO.	MAIN VO1 @*#=#		AUX. VO2 @*#=#▲		MAIN ±VO3 @*#♥	
	Typ.	Volt.	Typ.	Volt.	Typ.	Volt.
APS149VP-30	30.0A	+5.0V	4.0A	+12.0V	3.0A	12.0V
APS149VP-31	30.0A	+5.0V	4.0A	+12.0V	6.0A	5.0V
APS149VPT-050IM	17.5A	+5.0V	4.0A	+12.0V	2.0A	24.0V
APS149VP-32	30.0A	+5.0V	2.5A	+24.0V	3.0A	12.0V
APS149VP-33	30.0A	+5.0V	4.0A	+15.0V	3.0A	15.0V
APS149VP-390A	30.0A	+5.0V	12.0A	+3.3V	3.0A	12.0V
APS149VP-390B	30.0A	+3.3V	8.0A	+5.0V	3.0A	12.0V
APS149VP-391A	30.0A	+5.0V	12.0A	+3.3V	3.0A	15.0V
APS149VP-391B	30.0A	+3.3V	8.0A	+5.0V	3.0A	15.0V

QUAD OUTPUT (Under forced air cooling)

MODEL NO.	MAIN VO1 @*#=#		AUX. VO2 @*#=#▲		MAIN ±VO3 @*#♥		AUX. ±VO4 ♥●	
	Typ.	Volt.	Typ.	Volt.	Typ.	Volt.	Typ.	Volt.
APS149VP-40	30A	+5.0V	8.0A	+12.0V	2.0A	12.0V	2.0A	12.0V
APS149VP-41	30A	+5.0V	8.0A	+12.0V	4.0A	5.0V	3.0A	5.0V
APS149VPQ-050IIE	30A	+5.0V	8.0A	+12.0V	3.0A	12.0V	2.0A	5.0V
APS149VP-42	30A	+5.0V	4.0A	+24.0V	2.0A	12.0V	2.0A	12.0V
APS149VP-43	30A	+5.0V	6.0A	+15.0V	2.0A	12.0V	1.5A	15.0V
APS149VP-490A	30A	+5.0V	15.0A	+3.3V	2.0A	12.0V	2.0A	12.0V
APS149VP-490B	30A	+3.3V	15.0A	+5.0V	2.0A	12.0V	2.0A	12.0V
APS149VP-491A	30A	+5.0V	15.0A	+3.3V	1.5A	15.0V	1.5A	15.0V
APS149VP-491B	30A	+3.3V	15.0A	+5.0V	1.5A	15.0V	1.5A	15.0V
APS149VPQ-025DI E	30A	+2.5V	15.0A	+3.3V	4.0A	12.0V	2.0A	5.0V

Symbol: "*" OVP built-in. "@" Adjustable. "♥" Floating but not isolated output. "●" Installed with Post Regulator (P.R.). "#" Remote sensing.
 "▲" Installed with magnetic amplifier. "±" Positive or Negative selectable (factory set). "=" Active circuit current sharing.

MECHANICAL DIMENSIONS: MM [INCHES]

WEIGHT: 960.5g (33.88 Oz)

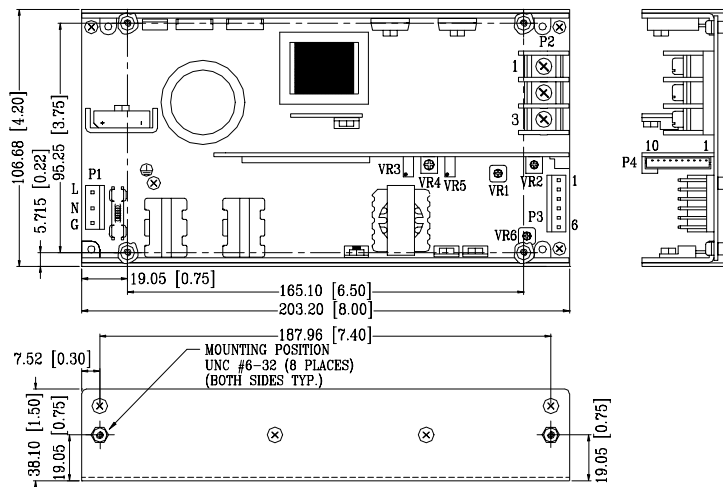

INPUT & OUTPUT CONNECTORS PIN ASSIGNMENT

ASSIGNMENT	AC INPUT			SINGLE/DUAL/ TRIPLE/ QUAD OUTPUT								ASSORTED SIGNALS								
	AC-LINE	AC-NEUTRAL	AC-GROUND	+VO1	VO2	DC-COM	VO3	-VO3	VO4	-VO4	DC-COM	ENABLE	POWER FAIL	DC-OK	+5V.S.B.	VO2=	VO2+S	VO1=	VO1/VO2-S	VO1+S
CNTR & PIN#	P1-5.	P1-3.	P1-1.	P2-2	P2-3.	P2-1.	P3-1,2.	P3-3,4.	P3-5.	P3-6.	P4-1.	P4-2.	P4-3.	P4-4.	P4-5.	P4-6.	P4-7.	P4-8.	P4-9.	P4-10.

Mating connector P1 & P3: Molex 5195, P4: Molex 5264.